

Design Analysis of an automatic corn cob packaging machine by CAD modelling and FEA

Lokesh Bhashyam, DR jeremy (Zheng)Li

Department of Mechanical Engineering/University of Bridgeport

ABSTRACT

The use of packaging medium is a normal practice in both small and big industries. This is mostly applied in granular materials like rice, beans and sugar. However, packaging is also done to other bit products that require the same for safety like corn cobs. Packaging of products makes it easier to transport to the market. In industrial application packaging of corn cob is not common. Most cases the cobs are removed from the cob and then packaged for sale. This project will be focusing on designing a packaging system, to be used in the manufacturing industry for faster and reliable packaging of corn cobs. The system will be packaging cobs of different sizes, from 6 to inches at a speed rate of 500 sweet corn cobs per hour. The machine will be fully automated and as such will be controlled using an industrial controller. The idea is to manually place the corn cobs on to the feeding conveyor belt, then the automatic packaging is done with the aim of reducing human efforts and time consumption. Finite Element Analysis (FEA) was also carried to determine quality control and failure to ascertain whether the machine would be safe for fabrication (Emmanuel O., 2021). The equipment designed by this software has a good stability, intuitive operating platform and convenient which improves the working performance and efficiency (Luo, 2022).

Date of Submission: 01-06-2024

Date of acceptance: 11-06-2024

I. INTRODUCTION

Packaging is an integrated system of preserving and preparing items until they are ready to be supplied to the end user, conveniently, cost-effectively and efficiently (D H Al-Janan, 2022). In an ever-changing world, there is major development in the food manufacturing industry in terms of food preservation and delivery. Food packaging is a very important step in the manufacturing of foods and its delivery to the markets. Food packaging involves how food items and products are packed, materials involved and the technology that makes it possible. Some of the major reasons to as why packaging of food is such an important aspect in the food industry is to extend the shelf life of the items as it protects the food items from environmental factors that may cause contamination, decay or damage in the transportation process, selling or storage. (Emmanuel Olatunji Olutomilola, 2021)

Machines have been developed to counter need for packaging of food items all over the world and most of which are automated with the aim of reducing human labor, increasing production and saving on costs. The automation farther increases production speed and allows businesses to meet higher demand and enhance overall efficiency

(Prathamesh Mulay, 2023). This has farther been made easier with the development of Computer-Aided design (CAD) which is now used by manufacturers as it increases productivity, materials used, time required for production and reduces labor.

The main aim of this project is to design an automated corn cob packaging machine and carry out Finite Element Analysis on the major parts of the designed machine. This is also made possible with the use of CAD applications with FEA possibilities to minimize errors, reduce overall operational costs that would otherwise be used in making prototypes and any damage to the object.

This project is conceived as a response to the challenge of meeting the consumer demands, envisioning a paradigm shift in sweet confection packaging through the strategic integration of automation and advanced technological tools.



Figure 1. Packaged Cob

II. METHODOLOGY

2.1 Literature review of available machines in the market.

2.1.1 Automatic food grain packing machine

This machine was developed by students from PSG College of Technology in India with the aim of increasing productivity of machines and reduce over reliance on human labor by automating it. The machine is operated by a Programmable Logic Controller (PLC) which automates the packaging and does so at higher speed. (PrabhakaranS, 2021)

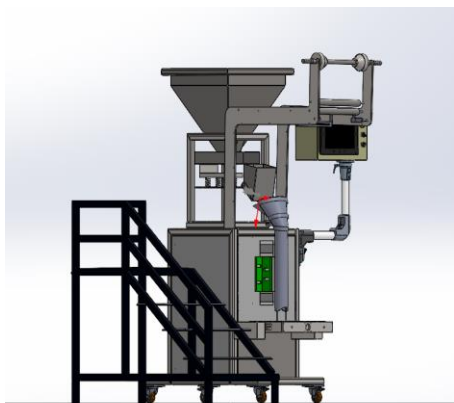

Figure 2. Grains packaging machine

<https://abmequipment.com/category/packaging-equipment/>

2.1.3 Thermoforming Vacuum Packaging Machine

This machine is a versatile for packaging food and other products keeping the visibility and moisture content intact and as such reducing derogatory oxygen content as low as possible and keeps the food fresh for long. It is automated and does not require manual bagging and this increases productivity, save packaging materials and manpower. (LLC, 2024).



Figure 3. Thermoforming Packaging machine

2.2 Design corn cob making machine using CAD software.

It is essential to use CAD software in the development process of a product as it offers several advantages over the use of manual design processes. The latter is time consuming and quality of work done was of low quality. Quality control can easily be done with the use of CAD as it allows for the parts to be clearly inspected. The use of CAD also allows for the simulation of performance of the designed object. It involves testing of the response of the designed object under forces, temperature, torque, stresses amongst other conditions as required.

The use of CAD is important as it also solves the problem of creating a prototype which is tedious, time consuming and expensive. Simulations allows for change in dimensions if any in order to meet the specifications which would be expensive in case of a prototype. It is then after the simulation is done that the designer is sure the object would not fail that a prototype is created for real life testing.

2.3 CAD Software Design

There is several CAD software that offer Finite Element Analysis applications. In this project Dassault Systemes Solidworks software is used as it comes with inspection, simulation, composer among other packages. It also has FEA capabilities and can perform dynamic and static analysis and as such the best for the project (al., 2020). The major parts of the Corn cob packaging machine designed are:

2.3.1 Conveyor system.

This system is made of a conveyor belt connected to the feeding section. This portion is made of stainless steel for durability and health safety. The conveyor system has a speed control column that allows the operator to increase or reduce the speed of the conveyor depending on the requirement. The feeding of the corn cobs is done manually to the conveyor belt as it moves to the packing section.

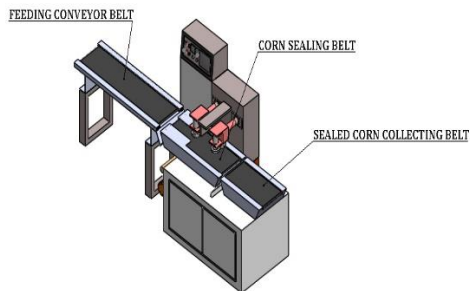

Figure 4. Conveyor systems (SOLIDWORKS)

2.3.2 Packaging Section

Consists of film holder that is underneath the end part of the feeding chamber conveyor. The film is the packaging material which is made of plastic and is used to cover the corn cobs. The holder is rotated by the gears which are connected and operated by a motor and allows the film to loosen as it moves up the two sealing points, one part that joins the two ends of the film, the middle section that heats up the ends of the film and the third portion that seals the heated part of the film and seals the film vertically. rotated up above to the sealing section.

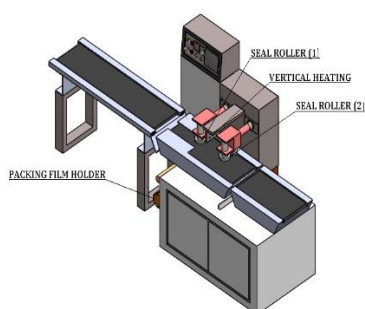

Figure 5. Sealing Section (SOLIDWORKS)

2.3.3 Vertical Sealing section

It is made up of two pairs of rotary rollers with a heating point in the middle. The rollers that rotate as they pick up the film around the corn cobs and does the vertical sealing as the sealing conveyor moves to the horizontal sealing section. The rotary rollers hold the film and as it rotates, they move the packaging film along the conveyor. (Qiuxiao Yang, 2015), (H. J. Zhang, 2015).

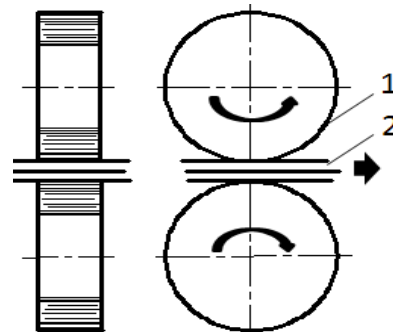

Figure 6. Vertical sealing mechanism

2.3.4 Horizontal Sealing section

This section has a sealing and cutting mechanism. When the vertically sealed wrapped cobs get to this section, two sharp knives are activated from below and above which seal and cut of the sealed section. The fully sealed corn cobs move to the collection belt.

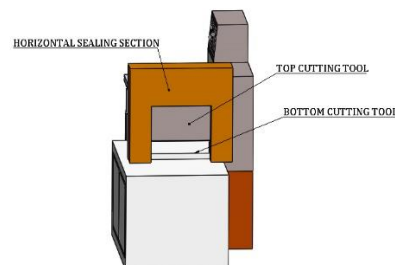

Figure 7. Horizontal Sealing section (SOLIDWORKS)

2.4 Simulation

In carrying out simulation, the designed object is subjected to conditions that are close to the real-world as possible. The object's materials must first be included before simulation is carried out, after which the required forces, torque, temperature, pressure or whatever factor that is required is applied and the software does all the necessary calculations.

2.4.1 Finite Element Modelling

This approach is used by CAD software to solve equations of physical phenomenon like force, torque, pressure etc. that are otherwise impossible to solve by hand for every point of the part of the said question. It subdivides the object part into small parts, called meshing where grids are created to define the subdivisions on the part (ERHUNMWUN, 2017), (SS, 1982).

The model, in 3D, is then exported to the FEA tool for simulation to be carried out. The FEA tool allows for complete correlation between the 3D

model used for analysis and the one manufactured and this helps in elimination of errors that could result in a case where a different FEA model was generated. In this analysis of FEA, it was ensured that English units was used as most results in the analysis are presented in metric format (Agonafer, 2020)

2.4.2 Types of FEA Analysis

In FEA, static and dynamic analyses can be performed. Static analysis is carried out when the object is subjected to pressure, force, torque, temperatures and when the object is not expected to be in motion during simulation. In static analysis, thermal analysis, deformation analysis and stress analysis are commonly performed. In this design project, static analysis is done.

2.5 Simulating the designed Corn Cob Packaging Machine

The FEA analysis was necessitated by the use of Solidworks software as it provides room for 3D model and FEA simulation. The CAD model was created using Solidworks and the workpiece simulated had a mass density of 8000 kg/m^3 . The temperature during simulation was 298K. The physical properties included were yield strength 172 MPa, tensile strength 580 MPa, Elastic modulus 193 MPa, Poisson's ratio 0.27. The mesh was set to high quality, with maximum element size being 318.359 mm and the minimum being 15.9179 mm. Blended curvature-based mesh was used with 16 high quality mesh Jacobean points.

The factors considered during the simulation were:

- i) The holders of the packing film were able to hold it as the rotate.
- ii) The stress on the conveyors would come from the force of the corn cobs.
- iii) The maximum amount of force on the conveyors would be 10N
- iv) The primary material for the work pieces is AISI 316 Stainless Steel.
- v) The factor of safety is 2.

2.5.1 Simulation results

In this simulation, Von mises stress analysis is the stress type analyzed. The minimum stress was 0 MPa and the maximum was 8.007 MPa. A downward displacement of 1.066 e-1 mm was also calculated. In addition, the maximum strain was 2.139 e-6 mm with a minimum being 0.

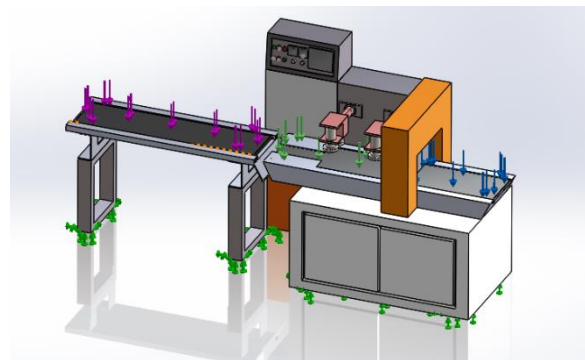

Figure 8. Model with forces applied

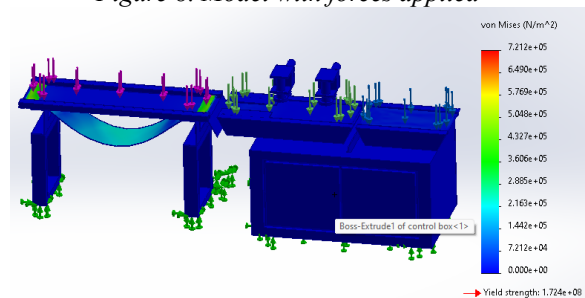

Figure 9. Von mises stress

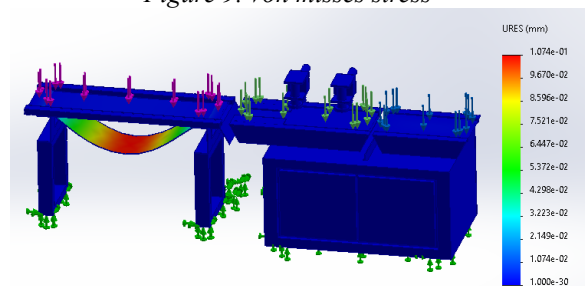

Figure 10. Displacement results

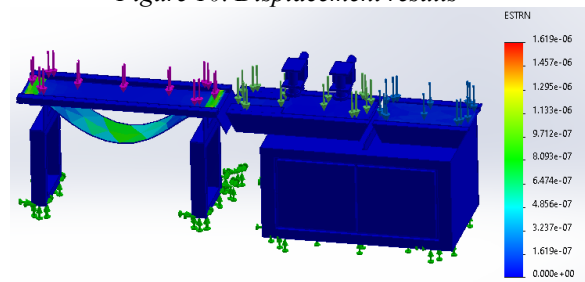

Figure 11. Strain analysis

The figures above depict the stresses, displacements and strains that the conveyors would undergo in association with the coordinate system of XYZ plane. The colors indicate the most affected regions with red showing the most affected region by the force applied and blue shows the safe region that is up to 1.619 e-6 mm from 0 mm.

III. DISCUSSION

The simulation done in this study are Von Misses stress which denotes the response of the workpiece to varying levels of stress. The desired results were isolated from nodes 69283 which produced minimum stress of $7.212 \times 10^4 \text{ N/m}^2$ and a maximum stress of $7.122 \times 10^5 \text{ N/m}^2$. The second simulation produced results of the workpiece at various displacement levels. The final simulation indicated how the object responded to different strain values, with desired outcomes traced from elements 36011 which attracted values of 1.619×10^{-7} and 1.457×10^{-6} . The factors above are critical as they determine the efficiency as well as show whether the desired outcomes are feasible. With a factor of 2 in place, means that the system can handle more than double the stipulated force without failing and thus it is safe. This also proves that the program is feasible and efficient.

It can be noted that the system can perform well in its area of application since the maximum stress recorded was far less than the yield strength and the tensile strength.

IV. CONCLUSION

With the integration of CAD to carry out Finite Element Analysis (FEA), the process becomes less tedious as it is automated and thus less time-consuming as compared to manual method.

The integration makes it much easier to carry out inspection and testing beyond. Consequently, the application of FEA methods to determine the quality and workability of the assembly is both feasible and possible as demonstrated by the analysis results above.

The use of CAD applications provides a much cheaper solution than creating prototypes as it allows for easier change of materials part and the dimensions during the test phase.

REFERENCES

- [1]. Agonafer, F. (2020). CAE/CAD Application To Electronic Packaging. ASME.
- [2]. al., C. e. (2020). CAD Driven Quality Systems. SAE International, 23.
- [3]. D H Al-Janani, K. R. (2022). Stress and displacement analysis of powder packaging machine. Earth and Environmental Science, 1.
- [4]. Daniel Sirkett, e. a. (2007). SIMULATION BASED DESIGN IN THE PACKAGING. INTERNATIONAL CONFERENCE ON ENGINEERING DESIGN, ICED'07, 1-3.
- [5]. Emmanuel O., S. P. (2021). Design and Finite Element Analysis of Flour Packaging Machine for Plantain Processing Plant. Mindanao Journal of Science and Technology, 269-270.
- [6]. Emmanuel Olatunji Olutomilola, S. P. (2021). Design and Finite Element Analysis of Flour Packaging. Mindanao Journal of Science and Technology, 275-280.
- [7]. ERHUNMWUN, I. (2017). Review on Finite Element Method. Journal of Applied Sciences and Environmental Management, 999-1000.
- [8]. H. J. Zhang, G. Q. (2015). Failure Mode Analysis of Heat Sealing Strength of Plastic Packaging Bag. Packaging Journal.
- [9]. Kurowski, P. M. (2015). Engineering Analysis with SOLIDWORKS' Simulation 2015. SDC Publication.
- [10]. LLC, L. M. (2024, February 13). Thermoforming Packaging Machine. Retrieved from lenis machines: <https://www.lenismachines.com/thermoforming-vacuum-packaging-machines/>
- [11]. Luo, D. (2022). Design and implementation of automatic packing machine system based on PLC. Frontiers in Computing and Intelligent Systems, 129-130.
- [12]. M., K. P. (2022). Engineering Analysis With SOLIDWORKS Simulation 2022. SDC Publications.
- [13]. PrabhakaranS, e. a. (2021). Design of Automatic Food Grain and Powder Packing Machine. Nat. Volatiles & Essent. Oils, 3200-3220.
- [14]. Prathamesh Mulay, D. K. (2023). Design and Manufacturing of Automatic Pouch Packing Machine. International Research Journal of Engineering and Technology (IRJET), 1506.
- [15]. Qiuxiao Yang, K. W. (2015). The Design and Research on Automatic Packaging Machine of the. International Conference on Management Science and Innovative Education, 355-356.
- [16]. RAJPUT, D. R. (n.d.). A TEXTBOOK OF STRENGTH OF MATERIALS. S. Chand Publishing.
- [17]. SS. (1982). The Finite Element Method in Engineering. Oxford, U.K: Pergamon Press.