

Effect of Friction Stir Welding Parameters on Welding Joint

Anwar y Alshatti & tariq a Alshatti

Abstract

Friction stir welding (FSW) has been used to join metallic and non-metallic materials without melting the base metal. this process employs a non-consumable rotary welding tool consist of a shoulder and a pin. the friction between the tool and the work piece generates heat which is coupled with the axial pressure on the tool contribute in the production of a permanent welding joint. this work reviews the influence of some operational and engineering parameters that may affect the performance of the friction stir welding and consequentially the mechanical properties of the welding joint..

Date of Submission: 12-12-2024

Date of acceptance: 25-12-2024

I. Introduction

Welding is the process of joining engineering materials using heat or pressure or both and with or without filler metal to form a permanent joint that cannot be dismantled without causing damage the two connected parts [1, 2]. In general, there are two main types of welding: fusion welding and non-fusion welding (solid state welding). Many traditional fusion welding techniques such as gas welding, arc welding, ...etc. have been successfully employed to join materials over the years. The work piece to be connected are melted at the joining interface during fusion welding, and typically a filler material is added to create a pool of molten material that solidifies to produce a strong joint.

Solid state welding types involve forge welding, explosive welding, ultrasonic welding, friction welding and friction stir welding (FSW) [3]. No external heat is applied to the joint area during solid-state welding. Only the heat generated by friction and plastic deformation during welding is sufficient to heat the base metal without melting it or adding any filler metal [3,4]. W.Thomas and his team from The Welding Institute (TWI) in Cambridge University/ United Kingdom devised friction stir welding in December 1991, these technique was originally used to joint low melting point alloys like aluminum, , copper, magnesium, and other metals [5,6].

Friction stir welding is a green welding technology for joining solid-state engineering materials without melting them. It is used to weld a wide range of alloys, particularly those that are difficult to weld using typical fusion welding methods [7]. Jointing or

friction welding is based on the idea that the procedure should be carried out without melting the components to be welded, as is the case with fusion welding, and that the metal should not be

heated above its melting point. W.J Arbegat and P.J. Hartley, [8] mentioned in the Fifth International Conference on Welding Research held in the United States in (June-1998) that the highest temperature reached by friction welding for different aluminum alloys is in the range (60-90 %) of its melting point, however Mohammed. M mulapear [5] explain in his research friction welding takes place at a temperature of (70-90%) of the melting point of the metal to be welded.

Friction stir welding is a solid state welding, it has a number of advantages over traditional fusion welding processes, including the absence of solidification cracks, no porosity, low distortion, and lower energy usage, pressure and deformation provide a large percentage of the bonding in these processes. In most cases, no melting of the base metal and no filler material is required, therefore there are fewer flaws occurs during welding. The atoms are then allowed to diffuse across the interface at a high temperature below the melting temperature of the work piece, filling any residual voids and completing the welding process [3,4,8].

Despite the benefits of using the friction stir welding technique, it has limitations that reduce the effectiveness of its use such as leaving a key hole when pulling out the welding tool at the end of each welding process, high vertical force is required with fasteners capable of clamping and holding the pieces in place, the rate of welding speed is slow compared to some types of fusion welding, therefore the welding process takes a relatively long time, and the height of the tool pin is designed according to the thickness of the work piece [9,10,11].

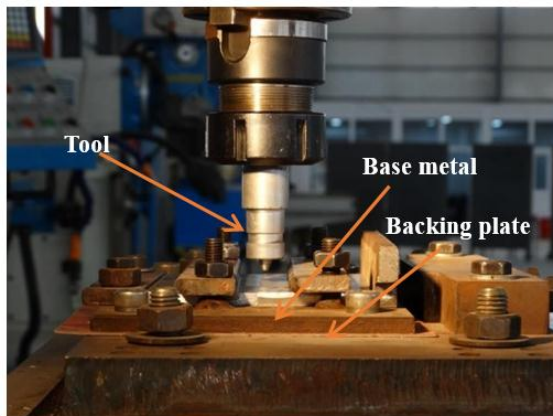

Fig. 1 Photograph showing the elements of FSW process

II. Friction stir welding parameters

Different parameters play a significant impact on the weldments quality during the friction stir welding process. These factors affect the flow, microstructure, heat distribution, and mechanical properties of plasticized metal [12].

These parameters can be classified into two main types:

1. Geometric parameters : such as the welding tool's design, type of welding tool metal as well as the pin and shoulder's shape and size [4,13].
2. Operational parameters : It contains the welding tool's rotational speed, linear speed, the angle of inclination of the welding tool (Tool Tilt Angle), the depth of penetration of the probe(pin), and the vertical forces applied to the welding area (axial load) [14].

III. Tool materials and design

Two main factors to consider when choosing the type of friction stir welding tool material are the weld quality required and the tool wear . In general, Welding tool must have the following characteristics:

- High Strength at high temperatures .
- High wear and fatigueresistance .
- High hardness .
- good machinability .
- It doesn't interact with the base metal being welded or the environment
- low thermal expansion coefficient and good thermal conductivity
- has a high fracture toughness .
- Ease of availability and cheapness [4,15].

IV. Tool pin profile

The tool is the key part in the whole friction stir welding process. it produces a welding joint under the thermo mechanical effect which is a

combination of the heat generated by friction and plasticizing the metal within the joint as the pin advances through this joint. The tool pin profile has a great effect on the quality of the joint produced by friction stir welding. changing the profile of the pin influences the amount of heat generated as a result of the friction between the pin and the metal, and also influences the flow of metal during the welding process [16]. Due to its significance, the profile of the tool pin has been an interesting point of research for many works to investigate its effect on the mechanical properties of different FSW joint.



Fig. 2 Photograph of FSW tool showing its different parts

4.1 Similar joint

Karthikeyan et al. [17] investigated the effect of tool pin geometry on AA6351 welding joints by FSW using square, cylindrical, and cylindrical threaded profiles. The welding joints by the square tool pin had the best tensile strength and hardness using rotation speed of 900 rpm. Later, Solanki et al. [18] studied the effect of the tool geometry on the impact strength of AA6351 joints by FSW using taper cylindrical pin with three different pin angles: 10°, 20°, and 30°(Fig.3) .

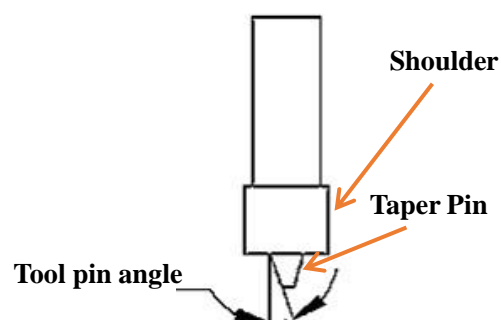

Fig. 3 Sketch of the tool pin angle

The joints that were produced by the tool pin with 10-degree taper pin angle had joints with the best impact strength. Goel et al. [19] studied the effect of tool geometry on welding joints of AA6063. Among the cylindrical, taper cylindrical, square, triangular, and hexagonal tool pins that were used in the study, the usage of the cylindrical tool pin produced weldments with the best tensile strength and impact strength due to the finegrains in the nugget zone (NZ) which improve the strength of the joint. The worst mechanical properties were obtained by the triangular tool pin. Rao et al. [16] compared the effect of the square and taper cylindrical tool pins on the mechanical properties of AA6061 joints. The welding joints by the square tool pin had better tensile strength and better hardness in the NZ with rotation speed of 1500 rpm and welding speed of 40 mm/min.

Compared with the straight cylindrical threaded and triangular threaded tool pins, J.M. Al-Murshdy and Q.K. Chabuk [20] found that the taper cylindrical tool pin produced welding joints of AA2024-T3 with the best tensile strength for its good ability to stir the metal during the welding process.

Shahabuddin and V.K. Dwivedi studied the effect of tool pin profile with different diameters of the tool shoulder and pin on the mechanical properties of AA 7075 FSW joints. They found that the square pin produced joints with best tensile and impact strengths. Furthermore, increasing the diameters of both the shoulder and the pin led to increasing the flow of metal during the welding process [21].

4.2 Dissimilar joint

Thimmaraju et al. [22] studied the effect of tool pin geometry in dissimilar joints of AA 6061 and AA 6082 using two constant operation speeds (1400 rpm, and 60 mm/min.) and three different shapes of the tool pin: square, cylindrical and taper. They obtained experimental and numerical data from which they could conclude that the cylindrical tool pin produced high-quality joints with better UTS and hardness. Using dissimilar joints of AA 5383 and AA 7075 friction stir welded by three different tool pins: cylindrical threaded, triangle, and cylindrical taper, Kumar and Anobumalar [23] proved that the triangular tool pin produced defect-free joint with superior tensile strength and hardness in the NZ. Another study on a dissimilar joint of AA 2014 and AA 6061 was carried out by Ramamurthy et al. [24] using five shapes of the tool pin: hexagon, conical, triangular, square, and pentagon. Their results agreed with that of Kumar and Anobumalar [23] as they found that the welding joints by the triangular tool pin were defect-free and

had the best tensile strength and hardness when the operation speeds of 1100 rpm and 25 mm/min. were employed.

Venkatashkannan et al. [25] used cylindrical, threaded, square, cylindrical taper, and stepped tool pins and constant operation speeds of 1000 rpm and 40 mm/min. to produce dissimilar weld joints of AA2024 and AA5052 by FSW. The joints by the stepped tool pin showed the best tensile strength and Hardness values. Deore and Hiwarkar [26] used cylindrical taper and square tool pins to weld dissimilar joints of AA6061 and AA5052 by FSW. The square pin produces weld joints with better mechanical properties using the optimum operation speeds of 1050 rpm and 36 mm/min. Ravikhmar et al. [27] studied the effect of tool geometry on dissimilar joints of AA6061-T652 and AA7075 - T651 using square, taper cylinder threaded, and taper square threaded tool pins. The best tensile strength and hardness in the NZ were obtained by the taper cylindrical threaded tool pin for its ability to well stir the metal during the welding process.

V. Axial load

It is one of the important FSW parameters and represents the amount of pressure applied on the welding tool, which has a direct effect on the amount of heat generated during the welding process. Figure (4) shows the effect of axial pressure during the welding process.

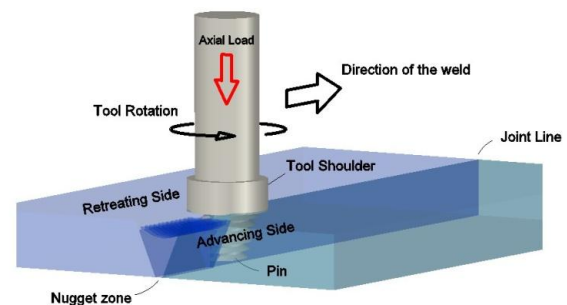

Fig. 4 Axial Load

M. Jayaraman et al. [28] studied the effect of axial load on the tensile strength of cast LM6. Four axial forces were applied (2-5 kN). The quality of welds was assessed by microstructural inspection. Free defect welds with best mechanical properties were produced by using 3 kN axial load. Increasing the axial load force resulted in increasing the hydrostatic pressure under the tool shoulder, and the temperature in the SZ which increases the flow of metal and generated uniformly-distributed, fine grains. Using axial forces (6-10 kN).

Rajakumar et al. [29] produced FSW joints of 7075-T6. The axial force of 8 kN produced the

best tensile strength, the highest HV values, and the highest welding efficiency of 77 % . They concluded that low axial force causes the formation of tunnel defects because of the insufficient flow of metal. Rose et al. [30] applied axial force (3-7 kN) to weld AZ 61A plates. Super mechanical properties were obtained using 5 kN axial load. Within the applied axial forces (3,4,5,6,7, and 8 kN) , Singh et al. [31] found that the welded joint of (6082-T651) by 6 kN had welded efficiency of 85 % . They concluded that high axial forces generate high amount of heat which caused the formation of flash defect and decreased the welding efficiency to 78 % .

Palanivel et al. [32] tested the effect of axial force in the range (1-2 ton) in a dissimilar joint of (AA 6351 –T6) and (AA 5083 –H11). They found that low axial force led to low heat and hydrostatic pressure under the shoulder which caused insufficient stirring of the metal in the joint, Sreenivas et al. [33] concluded that using an axial force more than 4 kN to joint 6082-T6 plates reduced the tensile strength. Mahany et al. [34] noticed that among the axial force (1000, 1150, 1300, and 1400 kN), the 1300 kN axial force produced the highest tensile strength joint of 7075-T6 and 2024- T6 plates. Increasing the axial force increased the grain size and hardness as a result of good stirring of the metal in the joint. Srinivasan et al. [35] fabricated FSW joints of Cast A413 AA using axial forces (2-7 kN).

The tensile strength and hardness increased up to 5 kN. Beyond 5 kN, coarse grains in the NZ resulted in the reduction of the mechanical properties. Al-jarah et al. [36] FSW joints of 6061 were fabricated under axial stress of (1.44, 3.62, 5.76, 7.82, and 10.07 MPa.). They found that the hydrostatic pressure and heat are proportional to the axial force. The tensile strength and hardness increased up to axial stress of 5.76 MPa. To assess the quality of AZ80 A Mg joint under axial force of (1-3 kN) were applied to produced FSW joint by Sevvil and Jaiganesh [37] The joints produced by 3 kN axial force had super mechanical properties with fine grains in the NZ.

VI. Operation Speeds

Patil and Soman [38] studied the effect of operation speeds on the mechanical properties and corrosion resistance of AA 6061-T6. Using four transverse speeds (55,60,65, and 70 mm/min.) and constant rotational speed of 1400 r.p.m. . The produced joints by 55 mm/min. had super mechanical properties and 49.32 welding efficiency. Increasing the transverse speed causes increasing in the corrosion resistance and reduction in the mechanical properties as the authors claimed.

Ugunder et al. [39] investigated the effect of the tool rotation speed in AZ31B FSW joints using four speeds (900,1120, 1400, and 1800 r.p.m) and constant welding speed. The operation speed 1400 rpm led to the highest tensile strength and impact strength. They concluded that the speed affect the mechanical properties of the FSW joints such that the increasing the rotation speed improved the tensile strength, Using AA 6063 friction stir welding joints with two rotational speeds (1000 and 1500 rpm) and two linear speeds (30 and 60 mm/min.) . Vaidyanathan et al. [40] found that the tensile strength improves with increasing linear speed and decreasing rotational speed. the optimum parameters were 1000 r.p.m. and 60 mm/min.

Santhkumar et al. [41] noticed that increasing the rotation speed improved the tensile strength in FSW joints of AA 2024 and AA 7075. Thakur and Ansari [42] confirmed that the rotation speed had more effect on the values of tensile strength. , the optimum parameters in FSW joints of 6063-T6 were 800 rpm and 40 mm/min. Kalemba et al. [43] found that increasing the rotation speed from 280- 560 rpm. in FSW dissimilar joints of AA 7075-T651/ AA 5083 H111 caused excess heat and coarse grains in NZ where reduced the mechanical properties.

Akinlabi et al. [44] noticed that increasing the transverse speed in FSW joints of 6082-T6 improved ultimate tensile strength , elongation, and hardness. Abtan et al. [45] concluded that better tensile strength was obtained in FSW joints of AA 6061-T4 by increasing the rotation speed and decreasing the welding speed, the optimum parameters were 2000 rpm and 20 mm/min. Which generated high friction heat and increased the flow of metal. Abbas et al. [46] studied the effect of operation speed in FSW dissimilar joint of AA 7475 / AA6061 using rotation speeds (1000, 1100, and 1200 rpm) and transverse speeds (90, 105, and 120 mm/min.) . They found that the using high rotation speed with low transverse speed resulted in high amount of heat and coarse grains in the NZ which decreased the mechanical properties according to Hall-Petch relationship.

Torzewski et al. [47] noticed that improper selection of operation speeds in the weldments of AA 7020 and weldments of AA 5083 led to reduce the quality of the welding as it caused the formation of tunnel and worm holes. Ghazvinloo and Shadfar [48] studied the effect of welding parameters on the quality of Al – 6% Si weldments using rotation speeds (800 -1200 rpm) and linear speeds (50 – 125 mm/min.). Lateral flash was formed when the joints was produced by low rotation speed (800 rpm) and linear speed (50 mm/min.). In addition, all the used speeds led to incomplete root penetration.

Tool tilt angle :

Tool tilt angle (TTA) as shown in the figure (5) it is represent the angle of inclination of the welding tool with respect to the normal to the work piece surface to increase the forging force which applied on the metal to improve the quality of the welded joints [49,50].

Mehtaa and Badheka [51] assessed effect of tilt angle (0° - 4°) on mechanical properties on a dissimilar joint of AA 6061-T651 and pure copper . The 4-degree tilt angle joints had super UTS : 166.6 Mpa.and HV hardness of 186. They found that high tilt angles improved the flow of metal and increases the axial pressure with defect-free joints. Shah et al. [52] tested 7075-T651 joint welded by different tilt angle (0° - 6°) . The two – degree tilt angle joints had superior mechanical properties and very fine grains in the welding zone [52].

Rajendran [53] studied the effect of tilt angle (0° - 4°) in AA 2014-T6 joints. The results revealed that the three – degree tilt angle joints had fine grains in SZ with better lap shear strength and hardness and welding efficiency of 84%. The study agreed with the Mehtaa [51] study about the effect of increasing the tilt angle on the flow of the metal in the welding zone .

With dissimilar joints of AA 2024/ AA 6061 and (0° - 3°) tilt angles, Ratnam et al. [54] found that better tensile strength obtained by using 2° tilt angle while better hardness obtained using 3° tilt angle .

Kuhbanani et al. [55] found that the best mechanical properties of polycarbonate friction stir welding joints were obtained using a tilt angle of 2.5° compared with other angles (0° - 4°). Up to 2.5° the joints were defect- free. Chitturi et al. [56] concluded that using a tilt angle of 2.5° to produce AA5052/ 304 stainless steel led to the best mechanical properties (shear force, hardness). Using 0° and 1.5° tilt angles led to the formation of defects in the SZ.

Rajendran et al. [57] performed experimental study to investigate the effect of the tilt angle on the mechanical properties of AA 2014-T6 friction stir welding joints. The study resulted in the fact that 2° was the optimum tilt angle from the strength point of view. The obtained welding efficiency was 84%. Kumar et al. [58] confirmed that the 2° tilt angle improved the mechanical properties of AA5083 FSW joint compared with 0° and 1° tilt angles.

Derazkola et al. [59] concluded that increasing the tilt angle from (0.5° - 4°) to join AA6068 using FSW increase frictional heat and the normal force on the surface of the metal .

In general , increasing the tool tilt angle improves mechanical properties of the FSW joints .

As it is clear from all the above studies the optimum tilt angle ranges from 2° - 3° .

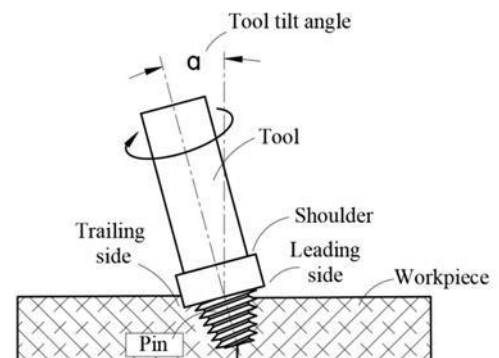

Fig. 5 Tool tilt angle

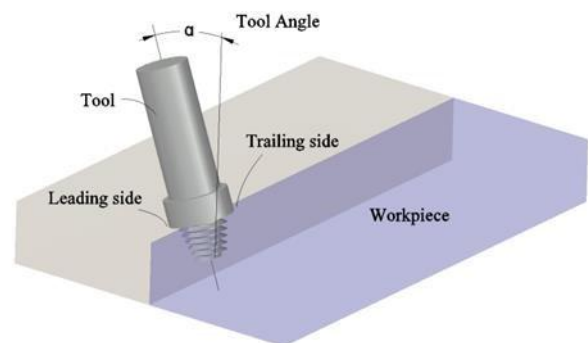

Fig. 6 Tool tilt angle (3-Dimension)

VII. Conclusions

Friction stir welding is a welding technique for joining metallic and non-metallic materials that may present a challenge during the fusion welding. This work reviews some of the main parameter of FSW for their effect on the performance and quality of the process such as operational speed, axial load, tilt angle, and tool profile. The selection of any of these parameters depends on the type of the joint materials and the desired mechanical properties of the joint which may differ from one application to another. Studying these parameters by many researchers, it has been proofed that the process of FSW should be well designed from the point of view of each of these parameters in order to create a flawless joint .

References

- [1] D.H.Philips, Welding Engineering An Introduction , 1st edition USA, Wiley & Sons,Ltd, 2016 .

- [2] J.Norish, *Advanced Welding Processes*, Cambridge, Woodhead Publishing Limited, 2006 .
- [3] M.P.Mubiayi, E.T.Akinlabi, and M.E.Makhatha, *Current Trend in Friction Stir Welding (FSW) and Friction Stir Spot Welding (FSSW)*, Switzerland, Springer International Publishing AG, 2019.
- [4] R. S. Mishra, M. W. Mahoney, "Friction Stir Welding and Processing", Rockwell Scientific Company, copyright 2007 ASM International, 2007.
- [5] M. M.Mulapeer, "Metallurgical and Mechanical Properties for Friction Stir Welding Aluminum Alloys [AA 2011, AA 7020, AA 7075] ,Degree of Doctor ,University of Salahaddin-Erbil,October 2009.
- [6] D. Lohwasser and Z. Chen, *Friction Stir Welding from Basics to Applications*, 1st ed. Great Abington, Cambridge CB21 6AH, UK, Woodhead Publishing Limited, Abington Hall, Granta Park, 2010.
- [7] B.R. Singh, *A Hand Book on Friction Stir Welding*, LAMBERT Academic Publishing, June 2012.
- [8] W.J. Arbegast, P.J. Hartley, in: *Proceedings of the Fifth International Conference on Trends in Welding Research*, Pine Mountain, GA, USA, June 1–1998, p. 541
- [9] F.C.Campbell, "Manufacturing Technology for Aerospace Structure Materials ", Elsevier Ltd, UK, 2006, ISBN-13:978-1-85-617495-4.
- [10] R. Naidu, "Friction Stir Welding :Thermal Effects of a Parametric Study on Butt and Lap Welds ", Degree of Master of Science, Shivaji University, India ,2003.
- [11] M.Dilek "Mechanical Properties of Different Aluminum Alloys Joined by Friction Stir Welding ", Degree of Master, University of Cukurova, Adana, Turkey, 2006.
- [12] K.S.Patel and A.K.Sarathe, " Effect of Tool Geometries on Thermal and Mechanical Behaviour of Friction Stir Welding Welds of Aluminum Alloy " , *American Journal of Engineering Research (AJER)*, Vol. 5, Issue 5, pp. 63-73, 2016.
- [13] F.Acerra et al., " On the FSW of AA2024-T4 and AA7075-T6 T-joints: an industrial case study ", *International Journal of Advanced Manufacturing Technology*, Vol. 48, Issue. 9-12, Jun 2010, pp.1149– 1157 ,2010 .
- [14] S. Rajakumar et al., " Influence of friction stir welding process and tool parameters on strength properties of AA7075-T6 aluminium alloy joints ", *Materials and Design Journal*, Vol.32 (2011), pp. 535– 549.
- [12] R. Rai et al., " Review: friction stir welding tools ", *Journal of Science and Technology of Welding and Joining*, Vol.16, No.4, pp.325-342,2011.
- [13] P.S.Rao et al., " Effect of Tool Geometrical Parameters on Friction Stir Welding Joint Properties of Aluminum Alloy AA6061 ", *ARPN Journal of Engineering and Applied Sciences*, Vol. 11, NO. 22, pp. 13053-13058, November, 2016 .
- [14] M.Karthikeyan and A.K.Dawood , " Influence of Tool Design on the Mechanical Properties and Microstructure in Friction Stir Welding of AA 6351 Aluminum Alloy ", *IRACST – Engineering Science and Technology: An International Journal (ESTIJ)*, Vol.2, No. 2, pp.233-237, April 2012.
- [15] M.T.Solanki et al., " Study the Effect of Tool Pin Taper Variation on Impact Strength of AA6351 Aluminum Alloy in FSW ", *IJSRD - International Journal for Scientific Research & Development*, Vol. 3, Issue 09, pp.971-974, 2015.
- [16] P.Goel et al., " Investigation on the Effect of Tool Pin Profiles on Mechanical and Microstructural Properties of Friction Stir Butt and Scarf Welded Aluminum Alloy 6063 ", *Metals*, Vol.8, Issue 74, January 2018.
- [17] J.M.Al-Murshdy and Q.K.Chabuk, " Effect of Tool Shape Geometry and Rotation Speed in Friction Stir Welding of 2024-T3 ", *The Iraqi Journal For Mechanical And Material Engineering*, Vol.16, No3, pp.176-185, 2016.
- [18] Shahabuddin and V.K.Dwivedi, " Effect of Tool Geometry of Friction Stir Welding on Mechanical Properties of AA-7075 Aluminum Alloy ", *International Journal of Mechanical Engineering and Technology (IJMET)*, Volume 9, Issue 6, pp. 625–633, June 2018 .
- [19] P.K.Thimmaraju et al., " Comparative Study of Influence of Geometry of tool pin Profile in Friction Stir Welding of Dissimilar Aluminum alloys using Experimental and Computational Methods ", *GRADIVA REVIEW JOURNAL*, Vol.7, Issue 7, pp.18-28, 2021.
- [20] P.M.Kumar and V.Anbumalar, " Effect of Pin Profiles on the Mechanical Properties of Friction-Stir-Welded AA 5383 and AA 7075 ", *Materials and technology*, Vol.54,

- Issue 1, pp.3-9, 2020. [24] M.Ramamurthy et al., " Influence of process parameters on the microstructure and mechanical properties of friction stir welds of AA2014 and AA6063 aluminum alloys using response surface methodology ", *Mater. Res. Express* 9 (2022).
- [25] V.M.et al., " Influences of Tool Geometry on Metallurgical and Mechanical Properties of Friction Stir Welded Dissimilar AA 2024 and AA 5052 ", *Procedia Engineering* 75 (2014), pp. 154 – 158, 2014.
- [26] H.Deore and V.Hiwarkar, " Effect of tool Geometry and process parameters on microstructure and mechanical properties of Dissimilar Friction stir welding of AA6061- AA5052 ", *Journal of Emerging Technologies and Innovative Research (JETIR)*, Vol. 6, Issue 4, April 2019 .
- [27] S. Ravikumar et al. , " Effect of Process Parameters on Mechanical Properties of Friction Stir Welded Dissimilar Materials between AA6061-T651 and AA7075-T651 Alloys ", *International Journal of Advanced Mechanical Engineering*, Vol. 4, Number 1, pp. 101-114, 2014.
- [28] M. Jayaraman et al., " Effect of Process Parameters on Tensile Strength of Friction Stir Welded Cast LM6 Aluminum Alloy Joints ", *J. Mater. Sci. Technol.*, Vol.25 No.5, 2009 .
- [29] S. Rajakumar et al., " Influence of friction stir welding process and tool parameters on strength properties of AA7075-T6 aluminum alloy joints ", *Materials and Design* 32 (2011) pp.535–549, 2011.
- [30] A.R.Rose et al., "Effect of axial force on microstructure and tensile properties of friction stir welded AZ61A magnesium alloy ", *Trans. Nonferrous Met. Soc. China* 21(2011), pp. 974–984, 2011.
- [31] G. Singh et al., " Effect of Axial Force on Mechanical and Metallurgical Properties of Friction Stir Welded AA6082 Joints ",*Advanced Materials Research* Vols. 383-390 (2012) pp. 3356-3360, 2012.
- [32]. R.Palanivel et al., "Effect of Tool Pin Profile and Axial Force on Tensile Behavior in Friction Stir Welding of Dissimilar Alloys ", *Advanced Materials Research* Vol. 415-417 (2012) pp. 1140-1146, 2012.
- [33] Sreenivas.P. et al., " Effect of Applied Axial Force on FSW of AA 6082-T6 Aluminum Alloys ", *International Journal of Mechanical Engineering and Technology (IJMET)*, Vol. 8, Issue 1, pp. 88–99, January 2017.
- [34] M. S. Mahany et al., " Influence of Tool Rotational Speed and Axial Load in Friction Stir Welding (FSW) of High Strength Aluminum Alloys ", *IJRET: International Journal of Research in Engineering and Technology* , Vol. 06 Issue: 02 , pp.114-120, Feb-2017 .
- [35] R.Srinivasan et al., " Effect of Axial Force on Microstructure and Mechanical Properties of Friction Stir Welded Squeeze Cast A413 Aluminum Alloy ", *Material Today, Proceedings*, 2017.
- [36] J.A.Al-Jarrah et al., "Effect of Applied Pressure on Mechanical Properties of 6061 Aluminum Alloy Welded Joints Prepared by Friction Stir Welding ", *Engineering, Technology & Applied Science Research*, Vol. 7, No. 3,pp. 1619-1622, 2017 . [37] Sevvel P and Jaiganesh V, " Effects of axial force on the mechanical properties of AZ80A Mg alloy during friction stir welding ",*Materials Today proceedings* 4 (2017), pp.1312–1320, 2017.
- [38] H.Patil and S.Soman , " Influence of Weld-Process Parameters on the Material Characterization of the Friction-Stir-Welded Joints of the AA 6061-T6 Aluminum Alloy ", *Materials and technology*, 47 (2013) 5,pp. 639–645 .
- [39] S. Ugender et al., " Influence of Welding Processes on Tensile Properties, Microstructure, and Hardness of Friction Stir Welded AZ31B Magnesium Alloy ", *Bonfring International Journal of Industrial Engineering and Management Science*, Vol. 4, No. 2, pp.96-100, May 2014 .
- [40] R. M.Vaidyanathan et al., " Effect of Process Parameters on Friction Stir Welding of 6063 Aluminum Alloy " , *International Journal of Design and Manufacturing Technology (IJDMT)*, Vol. 6, Issue 1, pp. 01-09, , January - April (2015) .
- [41] E. Santhkumar et al., " Experimental Analysis of Process Parameters in Friction Stir Welding Using Aluminum 2024 and Aluminum 7075 ", *International Journal of Advanced Engineering Technology*, Vol. VII/Issue II, pp.134-139, April-June,2016.

- [42] V. K. Thakur and A. R. Ansari, "Study the Effect of Tool Rotation Speed and Welding Speed on Mechanical Properties of Welded Aluminum Alloy (Welding through Friction Stir Process) ", *IJSRD - International Journal for Scientific Research & Development* Vol. 5, Issue 09, 2017 .
- [43] I. Kalemba et al. , " Effect of process parameters on mechanical properties of friction stir welded dissimilar 7075-T651 and 5083-H111 aluminum alloys", *The International Journal of Advanced Manufacturing Technology*, (2018) 97, pp. :2767–2779. [44] S. A. Akinlabi et al., "Effect of FSW on the mechanical properties and microstructure of 6082-T6 AA ", *IOP Conf. Series: Materials Science and Engineering* 423 (2018) 012163 .
- [45] N S. Abtan et al. , " Tensile Strength, Micro-hardness and Microstructure of Friction-Stir-Welding AA6061-T4 Joints ", *Tikrit Journal of Engineering Sciences*, Vol.25, Issue 4, pp.51-56, 2018.
- [46] V. Abbas et al. , " Effect of processing parameters on the mechanical properties and microstructure of the dissimilar aluminum alloys of AA7475 and AA6061 ", *International journal of research in engineering and innovation (IJREI)*, vol. 6, issue 1 ,pp. 69-76 . 2022.
- [47] J. Torzewski et al., " Microstructure and Mechanical Properties of Dissimilar Friction Stir Welded Joint AA7020/AA5083 with Different Joining Parameters ", *Materials* 2022, 15, 1910.
- [48] H. R. Ghazvinloo and N. Shadfar, " Effect of Friction Stir Welding Parameters on the Quality of Al-6%Si Aluminum Alloy Joints ", *Journal of Materials and Environmental Science*, Vol.11, Issue 5, pp. 751-758, 2020.
- [49] K.S.Petal and A.K.Sarathé, " Effect of Tool Geometries on Thermal and Mechanical Behavior of Friction Stir Welds of Aluminum Alloy ", *American Journal of Engineering Research (AJER)*, Vol. 5, Issue 5, pp. 63-73, 2016.
- [50] R.R.Kumar et al., " Evaluation of Processes Parameter and Mechanical Properties in Friction Stir Welded Steels ", *International Journal of Mechanical Engineering and Technology (IJMET)*, Vol. 8, Issue 2, pp. 183-193, February 2017.
- [51] K. P. Mehta and V.J. Badheka, , " Effects of tilt angle on properties of dissimilar friction stir welding copper to aluminum ", *Materials and Manufacturing Processes*, Vol.31, Issue 3, pp. 255-263, 2016.
- [52] P. H. Shah et al., " An Experimental Insight on the Selection of the Tool Tilt Angle for Friction Stir Welding of 7075 T651 Aluminum Alloys ", *Indian Journal of Science and Technology*, Vol. 9(S1), December 2016 .
- [53] Rajendran C et al. , " Effect of Tool Tilt Angle on Microstructural Characteristics of Friction Stir Welded Lap Joints of AA2014-T6 Aluminum Alloy Joints ", *Journal of Manufacturing Engineering*, , Vol. 12, Issue. 3, pp. 120-126, September, 2017.
- [54] CH. Ratnam et al. , " Optimization of Friction Stir Welding Parameters to Improve the Mechanical Properties of Dissimilar AA2024 and AA6061 Aluminum Alloys ", *International Journal of Mechanical and Production Engineering Research and Development (IJMPERD)*, Vol. 8, Issue 6, pp.937-944, Dec 2018.
- [55] H. M. Kuhbanani et al., "Effects of Tool Tilt Angle and Plunge Depth on Properties of Polycarbonate FSW Joint ", *Journal of Modern Processes in Manufacturing and Production*, Vol. 7, No. 4, Autumn 2018.
- [56] V. Chitturi et al. , " Effect of Tilt Angle and Pin Depth on Dissimilar Friction Stir Lap Welded Joints of Aluminum and Steel Alloys ", *Materials* 12, 3901, 2019.
- [57] C. Rajendran et al. , " Effect of tool tilt angle on strength and microstructural characteristics of friction stir welded lap joints of AA2014-T6 aluminum alloy ", *Trans. Nonferrous Met. Soc. China* 29(2019) pp.1824–1835, 2019.
- [58] R S.Kumar et al. , " Optimization of FSW Parameters to Improve the Mechanical and Metallurgical Properties of Aluminum Alloy AA 5083 Joints ", *Materials Science and Engineering* 912 (2020) 032029 , 2020.
- [59] H. A. Derazkola et al. , " Effects of friction stir welding tool tilt angle on properties of Al-Mg-Si alloy T-joint ", *CIRP Journal of Manufacturing Science and Technology*, 33 (2021), pp. 264–276, 2021.