

Steps for parallel transformers connection with different types of loads

Abdullah Alsultan ⁽¹⁾, Adnan Alharees ⁽²⁾

Electrical Networks Department, High Institute of Energy, Public Authority of Applied Education and Training, KUWAIT

Paper objective:

The objective of the experiment study is to recognize the steps of connection and conditions of synchronizing two lab transformers in parallel and study the effect of different types of loads. The experiment held in the High Institute of energy transformers lab by Eng. Abdullah Alsultan and Eng. Mohammed Alkandari both are members of training staff of electrical network department. The types of Loads used are **resistance, capacitance, and Inductance** load.

Date of Submission: 09-10-2023

Date of acceptance: 22-10-2023

If the conditions for the parallel connection of the transformers are not met, short current arise leads to damage the transformers, the circuit breakers and all circuit related to the connection will have the potential of damage.

*Note:

In case of parallel connection two, the power ratio of the larger transformer to the smaller one must not exceed 1/3. In other words, if the larger transformer has a capacity of 240 KVA, it is not permissible to connect a transformer in parallel with it that have a capacity less than 80 KVA.

Discussion :

When the load on a transformer exceeds its capacity, one of the methods used is to connect a second transformer in parallel to divide the required load consumption. And In order to ensure the correctness of the connection and distribution of the load the following conditions must be met:

- 1- The voltage conversion ratio of the transformers should be the same.
- 2- The impedance percentage of the transformers should be the same.
- 3- The same polarity connection should be met.

The main goal of this paper is to measure and test the values of a single-phase transformers in parallel and to take the Measurement of the total load distribution between them, so we can study the effect of load type (resistive - inductive - capacitive).

The transformers should have the same phase sequence, the same relative displacement, vector group, and condition above are essential and must be achieved first. Otherwise, the current will circulate between the two transformers, and since

I. Discussion:

• The benefits of connecting transformers in parallel

By using two or more transformers in parallel, we can maneuver better than using one large transformer during shut down or maintenance of a transformer, that option males the power continually available to customers. Moreover, the lifetime of transformers could last longer due to the distribution of power among multiple transformers. Other benefit is during the routine maintenance, we do not have to dis connect the supply of power on customers, simply we distribute it to other connected ones.

• Connection conditions of parallel transformers

there are some conditions for parallel transformer connection must be met before connecting two transformers in parallel, the following rules must be met:

- 1- The relative voltage drop should be numerically equal in both transformers and compatible in phases.
- 2- The polarity of the terminals should be considered when connecting, so the terminals of similar polarity should be connected.
- 3- The short circuit voltage (Vsh) must be equal in both transformers.
- 4- The connection systems (group) for the windings in the first transformer must be like the connection systems in the second transformer, for example if the system in the first transformer is (Y-Y), the second transformer should be (Y-Y).

leads to the two transformers sharing the load equally, and this should be proven by measurement. Regarding the voltage V_{out} , the type of load affects its value, as the inductive load causes a drop more than the resistive load, while the capacitive load causes a rise in the voltage (negative voltage regulation).

the value of impedance in the circuit is small, circulating current may reach high values, depending on the value of the difference between the conversion ratios, which must be close to a high degree of accuracy.

Given that the two transformers under test are identical, it is expected that they will have the same value of the percentage impedance, which

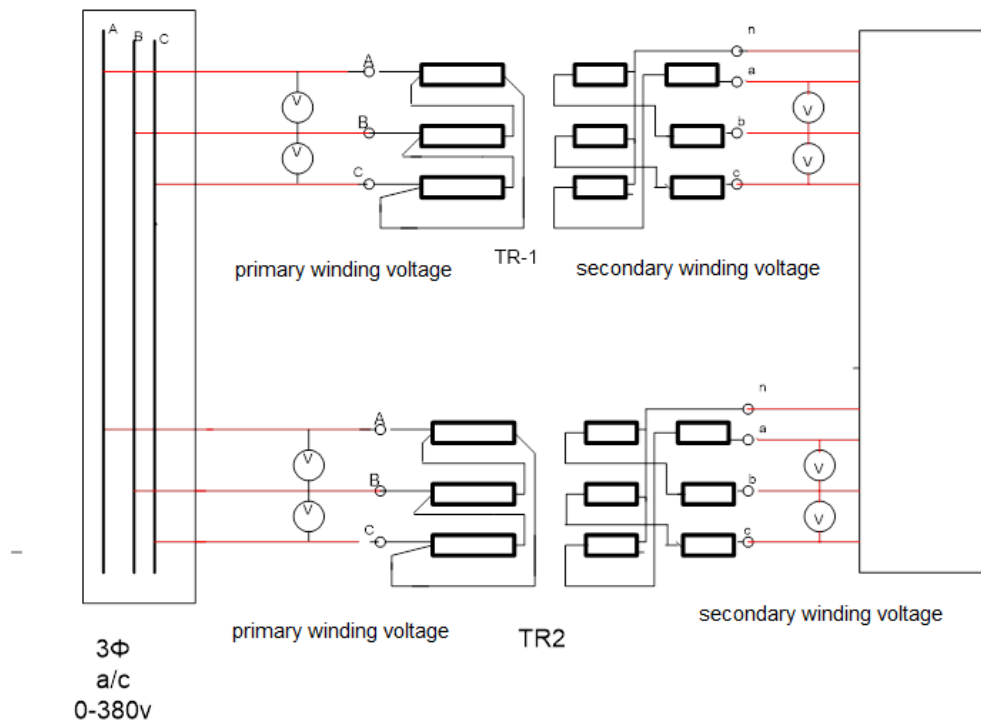

- 5- Using the direction of rotation device, check the direction of rotation of the phase of both transformers and make sure that the direction of rotation of both transformers are the same.
- 6- Before connecting the secondary windings together in parallel, we start connecting terminals of the transformer together.
- 7- Measure the voltage difference between terminal b of the first transformer and terminal b of the second transformer and record the reading: the voltage difference between the two terminals = 0 volts.
- 8 - If the potential difference is zero, connect the b terminals of the first transformer to the b terminal of the second transformer.
- 9 - Measure the voltage difference between terminal c of the first transformer and terminal c of the second transformer and record the reading: the voltage difference between the two terminals = 0 volts.

Tools and devices used:

- 1- Laboratory Transformers Mv Ct 1931.
- 2- Rotational direction selector in single-phase system.
- 3- AC voltmeters from 0 to 500 volts.
- 4- AC ammeters from 0 to 10 amps.
- 5- One- phase ammeters.
- 6- Matching wires.
- 7- Lab resistors load.
- 8- inductor loads.
- 9- capacitor loads.

Action steps and results:

- 1- Write down the data on the data plate for both transformers.
- 2- Ensure that the two transformers are isolated from the source.
- 3- Put the voltage changer for both transformers on the number (1).
- 4- Connect the terminals of the two transformers to the single-phase voltage sources.

10 - If the potential difference is zero, connect the c terminal of the first transformer to the c terminal of the second transformer.

Single phase transformer connection

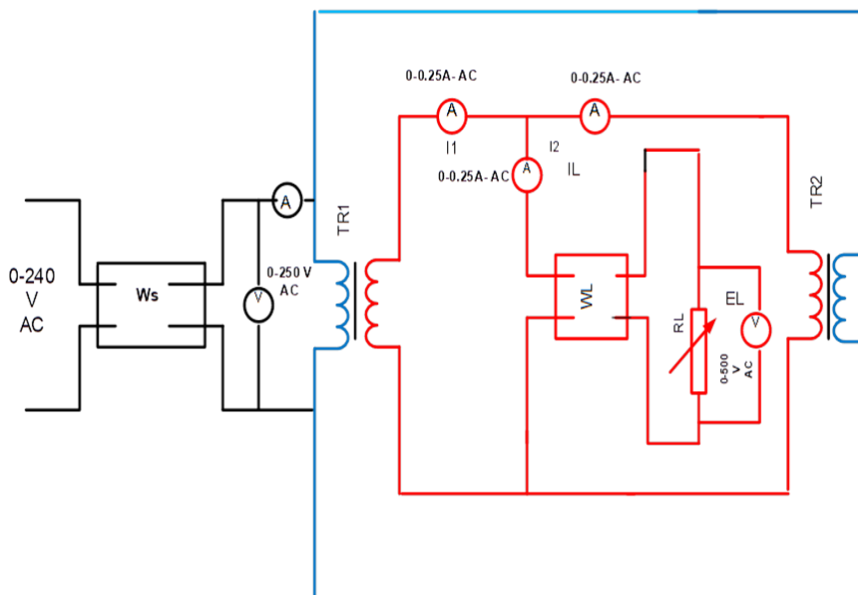

First: - observation of resistive load - source readings

Total source current from primary side	1.5A
Total source voltage from primary side	300 V
Source total power (Pin)	390 W
Calculate power for each transformer (VA)	165 168
Calculate source power factor (P/S)	0.866

Record the readings at the secondary winding side with the load

	TR1	TR2
Secondary winding current	0.55A	0.56A
Total load current	1.4A	
Total load voltage	290V	
Total load power	300W	
Total power of the transformer	159.5 VA	162.4 VA
Power factor of the load	0.738	
Power loss of the load	90 W	
quality calculation	76.9%	

The load is distributed approximately evenly to the transformers and the load voltage decreased

Second:- observation of Inductive load - source readings

Total source current from primary side	1.8A
Total source voltage from primary side	300 V
Source total power (Pin)	100 W
Calculate power for each transformer (VA)	240 VA 270 VA
Calculate source power factor (P/S)	0.55

Record the readings of the secondary winding and the load

	TR1	TR2
Secondary winding current	0.8A	0.7A
Total load current	1.7A	
Total load voltage	300V	
Total load power	50 W	
Total power of the transformer	240 VA	210 VA
Power factor of the load	0.588	
Power loss of the load	50 W	
quality calculation	50 %	

The voltage did not change with evenly distributed load.

Third - Record the readings of the meters in the table for the capacitors load of the source

Total source current from primary side	1.6A	
Total source voltage from primary side	300 V	
Source total power (Pin)	50 W	
Calculate power for each transformer (VA)	240 VA	240 VA
Calculate source power factor (P/S)	0.104	

Record the readings of the secondary winding and the load

	TR1	TR2
Secondary winding current	0.8A	0.8A
Total load current	1.6A	
Total load voltage	3200V	
Total load power	0 W	
Total power of the transformer	256 VA	256 VA
Power factor of the load	0	
Power loss of the load	50 W	
quality calculation	0 %	

The load voltage increased as the load is capacitive.

II. Conclusion

as the condition of connecting two transformers in parallel: as previously mentioned, met, we can conclude that the load was distributed evenly. The inductive and resistive loads consumed some power as the capacitive load consumed zero power. And we can note that the voltage did not change for the inductive load and slightly decreased for resistive load. Where the capacitive load increased the voltage as expected. The conducted experiment applied the rules of parallel transformers connection, thus, the circulating current between the two transformers are zero which means that both transformers are feeding the load not each other.