

RESEARCH ARTICLE

Wind Generator (Dfig) Based Statcom Controller

B.Raghu, k.Suresh

1Post Graduate Student (M.Tech), Rajeev Gandhi memorial college ofEngineering(Autonomous),
Nandal,AP-India.

2Assistant Professor, Department of EEE,Rajeev Gandhi memorial college of Engineering (Autonomous),
Nandal, AP-India,

Abstract:

In the grid new renewable resources are added to extract more power. This adds more power quality issues to grid connection. A Power quality problem is an occurrence manifested as a nonstandard voltage, current or frequency that results in a failure or a mis-operation of end user equipment. This paper investigates the use of a static synchronous compensator (STATCOM) is connected at a point of common coupling with Battery Energy Storage System(BESS) to overcome of a power quality issues of a wind farm equipped with variable speed wind turbines driving Double – Fed Induction Generators (DFIG). The wind turbine performance and power quality are determined according to the norms of International Electro-technical Commission standard, IEC-61400. The STATCOM control scheme for the grid connected wind energy generation system for power quality improvement is simulated using MATLAB/SIMULINK in power system block set. The effectiveness of the proposed scheme relieves the main supply source from the reactive power demand of the load and the induction generator. The development of the grid co-ordination rule and the scheme for improvement in power quality norms as per IEC-standard on the grid has been presented.

Index terms-International electro-technical commission (IEC), doubly-fed induction generator (DFIG), point of common coupling, STATCOM, Battery Energy Storage System(BESS).

1. INTRODUCTION

The conventional energy sources such as oil, natural gas, coal, or nuclear are finite and generate pollution. Alternatively, the renewable energy sources like wind, fuel cell, solar, biogas/biomass, tidal, geothermal, etc. are clean and abundantly available in nature. Among those the wind energy has the huge potential of becoming a major source of renewable energy for this modern world. Wind power is clean, emissions-free power generation technology. Wind energy systems employ various installations to exploit wind energy such as synchronous or squirrel-cage and doubly fed asynchronous machines (DFIG). The changing of wind speed has an effect on the considered power transfer. In general, the efficiency of variable-speed systems is higher compared to the one of fix-speed systems. DFIG wind turbines are nowadays more widely used especially in large wind farms. The main reason for their popularity when connected to the electrical network is their ability to supply power at constant voltage and frequency while the rotor speed varies, which makes it suitable for applications with variable speed. Additionally when a bidirectional AC-AC converter is used in the rotor circuit, the speed range can be extended above its synchronous value recovering power in the regenerative operating mode of the machine.

aspect[8]. Currently the growth of wind power generation is very fast throughout the world. Voltage flicker is one of the most important power quality aspects that should be reduced to enable the quality of electric power. The reason behind voltage Flicker is fluctuations, which are developed by load variations in the grid system[1].

The incorporation of Doubly Feed Induction Generators (DFIG generators) in wind turbines, improves stability and frequency of the voltage through their decoupled control of active and reactive power.

However, the power delivered by the wind farm to the electricity network presents many defects. Below are some of them:

- Flicker, which is understood to be the sensation that is experienced by humans when subjected to changes in illumination intensity. The human maximum sensitivity to illumination changes is a frequency range between 5Hz to 15Hz. The fluctuating illumination is caused by amplitude modulation of the feeding alternating voltage. It is particularly important in weaker grids. Wind variations cause power variations [13], [4].
- Frequency fluctuations due to power fluctuations.

- Harmonic emission due to the presence of electronic power converters in wind turbines.
- Voltage fluctuations due to aerodynamic aspects of wind turbines [3].

In order to promote the integration of wind farms into the electrical network, Flexible AC transmission Systems, FACTS, are widely used. The FACTS STATCOM system is one of them. STATCOM has some advantages, such as better performance, quick response, smaller in size, less cost, and capable of satisfying both active and reactive power requirements. This method is suitable for the applications with frequently fluctuating loads and power flow.

By using high frequency switching PWM, the high speed switching converter will generate smooth current with low harmonic content. STATCOM provides or absorbs reactive power to or from the grid to compensate small voltage variations at the connection point of the wind farm with the grid. STATCOM is also used when a voltage dip occurs.

The paper is organized as follows. The Section II introduces DFIG Wind turbine system. The Section III introduces the power quality standards, issues and its consequences of wind turbine and the grid coordination rule for grid quality limits. The Section IV describes the topology for power quality improvement. The Sections V, VI, VII describes the control scheme, system performance and conclusion respectively.

II. The Doubly Fed Induction Generator (DFIG)

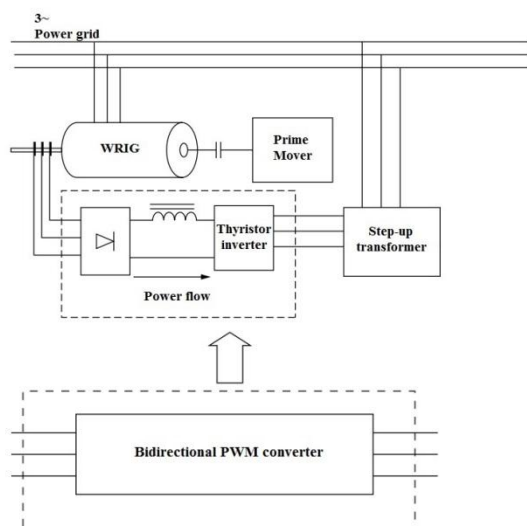

Fig 1: Doubly-fed induction generation system power flows.

Nowadays, over 85% of the installed wind turbines utilize DFIGs [6]. In the DFIG topology, the stator is directly connected to the grid through transformers and the rotor is connected to the grid through PWM power converters. The converters have the capability of generating or absorbing reactive power and could be used to control the reactive power or the voltage at the grid terminals. The rotor-side converter is used to control the wind turbine output power and the voltage (or reactive power) measured at the grid terminals. The grid-side converter is used to regulate the voltage of the DC bus capacitor. It's also used to generate or absorb reactive power. The three-phase rotor winding is connected to the rectifier by slip rings and brushes and the three-phase stator winding is directly connected to the grid. A step-up transformer is necessary for voltage adaption, while the thyristor inverter produces constant voltage and frequency output. The principle of operation is based on the frequency theorem of traveling fields.

$$f_1 = np_1 + f_2 ; f_2 \ll 0,$$

and variable $f_1 = ct$ (1)

Negative frequency means that the sequence of rotor phases is different from the sequence of stator phases. Now if f_2 is variable, n may also be variable, as long as Equation 1 is fulfilled.

That is, constant frequency f_1 is provided in the stator for adjustable speed. The system may work at the power grid or even as a stand-alone, although with reconfigurable control.

When $f_2 > 0$, $n < f_1/p_1$ we have sub synchronous operation. The case for $f_2 < 0, n > f_1/p_1$ corresponds to hypersynchronous operation. Synchronous operation takes place at $f_2 = 0$, which is not feasible with the diode rectifier current source inverter, but it is feasible with the bidirectional PWM converter. The slip recovery system can work as a sub synchronous ($n < f_1/p_1$) motor or as a super synchronous ($n > f_1/p_1$) generator. The WRIG with bidirectional PWM converter may work as a motor and generator for both sub synchronous and super synchronous speed. The power flow directions for such a system are shown in Figure 2a and Figure 2b. The converter rating is commensurate to speed range, that is, to maximum slip S_{max} :

$$KVA_{rating} = K \frac{f_{2max}}{f_1} \times 100[\%] \quad (2)$$

$K = 1-1.4$ depending on the reactive power requirements from the converter.

Notice that, being placed in the rotor circuit, through slip-rings and brushes, the converter rating is around

$|S_{max}|$ in percent. The larger the speed range, the larger the rating and the costs of the converter. Also, the fully bidirectional PWM converter — as a back-to-

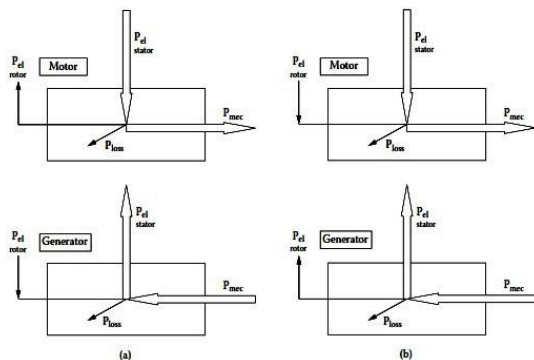

Fig 2: Operation modes of DFIG with bidirectional pulse-width modulator (PWM) converter (in the rotor): (a) $S < 0$ and (b) $S > 0$.

back voltage source multilevel PWM converter system — may provide fast and continuous decoupled active and reactive power control operation, even at synchronism ($f_2 = 0$, DC rotor excitation). And, it may perform the self-starting as well. The self-starting is done by short-circuiting the stator, previously disconnected from the power grid, and supplying the rotor through the PWM converter in the sub-synchronous motoring mode. The rotor accelerates up to a prescribed speed corresponding to $f_2 > f_1(1 - S_{max})$. Then, the stator winding is opened and, with the rotor freewheeling, the stator no load voltage, sequence and frequency are adjusted to coincide with that of the power grid, by adequate PWM converter control. Finally, the stator winding is connected to the power grid without notable transients. This kind of rotor-starting procedure requires $f_2 \approx (0.8 - 1)f_1$, which means that the standard cycloconverter is out of the question. So, it is only the back-to-back voltage PWM multilevel converter or the matrix converter that is suitable for full exploitation of motoring/generating at sub- and supersynchronous speeds. [2]

III. POWER QUALITY STANDARD ISSUES AND ITS CONSEQUENCES

3.1. International Electro Technical Commission Guidelines

The guidelines are provided for measurement of power quality of wind turbine. The International standards are developed by the working group of Technical Committee-88 of the International Electro-technical Commission (IEC), IEC standard

61400-21, describes the procedure for determining the power quality characteristics of the wind turbine [4]. The grid quality characteristics and limit are given for references [10]-[11] that the customer and the utility grid may expect.

The standard norms are specified.

- 1) IEC 61400-21: Wind turbine generating system, part-21. Measurement and Assessment of power quality characteristic of grid connected wind turbine
- 2) IEC 61400-13: Wind Turbine—measuring procedure in determining the power behaviour.
- 3) IEC 61400-3-7: Assessment of emission limit for fluctuating load IEC 61400-12: Wind Turbine performance.

The data sheet with electrical characteristic of wind turbine provides the base for the utility assessment regarding a grid connection.

3.2. Voltage fluctuation on grid:

The power fluctuation from wind turbine during continuous operation causes voltage fluctuation on grid. The amplitude of this fluctuation depends on grid strength, network impedance, and phase angle and power factor [3]. The voltage fluctuation and flicker are caused due to switching operation, pitch error, yaw error, fluctuation of wind speed. Today, the measurement and assessment of power quality on grid connected wind turbine is defined by IEC 61400-21 and stated that the 10 minute average of voltage fluctuation should be within +/- 5% of nominal value. If the voltage is rising, then the amount of voltage rise is, denoted by 'u'

$$u = \frac{S_{max}}{S_k} [\cos(\Psi_k + \varphi)] \quad (3)$$

Where S_{max} - Max. Apparent Power, S_k - Short circuit power, Ψ_k - Network impedance phase angle, φ - phase difference. The limiting value is <2% - 10%

3.3. Voltage dips on the grid (d).

It is a sudden reduction of voltage to a value between 1% & 90 % of nominal value after a short period of time, conventionally 1ms to 1 min. This problem is considered in the power quality and wind turbine generating system operation and computed according to the rule given in IEC 61400-3-7 standard, "Assessment of emission limit for fluctuating load". The start-up of wind turbine causes a sudden reduction of voltage. The relative % voltage change due to switching operation of wind turbine is calculated as equation (1).

$$d = 100 K_u(\Psi_k) \frac{S_n}{S_k^*} \quad (4)$$

where d – relative voltage change.

$K_u(\Psi_k)$ – Voltage change factor.

S_n – Rated apparent power of wind turbine and

S_k^* – Short circuit apparent power of grid

The voltage dips of 3 % in most of the cases are acceptable. When evaluating flicker and power variation within 95% of maximum variation band corresponding to a standard deviation are evaluated.

3.4. Switching operation of wind turbine on the grid.

Switching operations of wind turbine generating system can cause voltage fluctuations and thus voltage sag, voltages well that may cause significant voltage variation. The acceptances of switching operation depend not only on grid voltage but also on how often this may occurs. The maximum number of above specified switching operation within 10-minute period and 2-hr period are defined in IEC 61400-3-7 Standard. It is due to the switching operation and the limiting Value is about $\pm 4\%$ of rated voltage.

3.5. Reactive Power

When wind turbine is equipped with DFIG with a four-quadrant converter in the rotor circuit enables decoupled control of active and reactive power of the generator. In DFIGs, active power is used to evaluate the power output and reactive power is responsible for its electrical behaviour in the power network. The DFIG requires some amounts of reactive power to establish its magnetic field. In case of grid-connected systems, the generator obtains the reactive power from the grid itself [15].

According to IEC Standard, reactive power of wind turbine is to be specified as 10 min average value as a function of 10-min.output power for 10%, 20%,..., 100% of rated power. The effective control of reactive power can improve the power quality and stabilize the grid. The suggested control techniques capable of controlling reactive power to zero value at point of common connection (PCC).

3.6. Harmonics

A wind electric generator directly connected to the grid without a fast acting power electronic switching converter is not expected to distort the fundamental waveform. The addition of Power electronics switches used for soft start and stop may generate high order current harmonics for short duration but their magnitudes are small. The DFIG wind turbines using power electronic converters for these reasons should be assessed

against specified or calculated limits for harmonics. The harmonics voltage and current should be limited to acceptable level at the point of wind turbine connection in the system. The IEC 61000-3-6 gives a guideline and harmonic current limits. The harmonic current I_h at PCC in the installation with a number of wind turbines can be computed as in (5).

$$I_h = \beta \sqrt{\sum_{i=1}^n \left[\frac{I_{hi}}{V_i} \right]^\beta} \quad (5)$$

where I_h is the order of harmonic current distorted at PCC, β is exponent harmonic order and it is 1 when $h \leq 5$ and 2 when $h > 10$.

The total harmonic voltage distortion of voltage is given as in (6):

$$V_{THD} = \sqrt{\sum_{H=2}^{40} \frac{V_n^2}{V_1}} \times 100 \quad (6)$$

Where V_n is the nth harmonic voltage and V_1 is the fundamental frequency (50) Hz. The THD limit for 132 KV is $< 3\%$.

THD of current I_{THD} is given as in (7)

$$I_{THD} = \sqrt{\sum \frac{I_n}{I_1}} \times 100 \quad (7)$$

Where I_n is the nth harmonic current and I_1 is the fundamental frequency (50) Hz. The THD of current and limit for 132 KV is $< 2.5\%$

3.7. Grid Frequency:

The grid frequency in India is specified in the range of 47.5–51.5 Hz, for wind farm connection. The wind farm shall able to withstand change in frequency up to 0.5 Hz/s [9].

3.8. Wind Turbine Location in Power System

The way of connecting the wind generating system into the power system highly influences the power quality. Thus the operation and its influence on power system depend on the structure of the adjoining power network.

IV. TOPOLOGY FOR POWER QUALITY IMPROVEMENT

According to the IEEE, STATCOM (static synchronous compensator) is a shunt controller injects current into the system at the point of connection in order to compensate the reactive power requirements of induction generator as well as load. The proposed ST ATCOM control scheme for grid connected wind energy generation for power quality improvement has following objective.

- Reactive power support from STATCOM to wind generator and load thereby maintaining unity power factor.

The proposed grid connected system is implemented for power quality improvement at point of common coupling (PCC), as shown in Fig. 3. It consists of wind energy generation system and battery energy storage system with STATCOM. The STATCOM is considered for this application, because it provides many advantages, in particular the fast response time (1~2 cycles) and superior voltage support capability with its nature of voltage source [8]. With the recent innovations in high-power semiconductor switch, converter topology and digital control technology, faster STATCOM (quarter cycle) with low cost is emerging [9], which is promising to help integrate wind energy into the grid to achieve a more cost-effective and reliable renewable wind energy.

4.1. Wind Energy Generating System

In this configuration, wind generations are based on variable speed topologies with pitch control turbine. Amount of power that wind turbines can extract from wind can be expressed as:

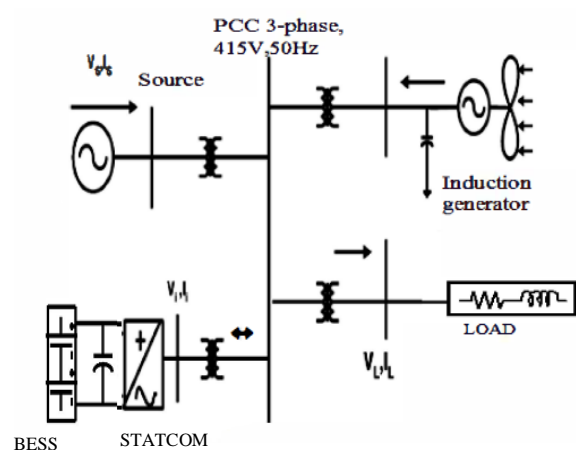

Fig 3. Grid connected system for power quality improvement.

$$P_m = C_p P_w \quad (8)$$

$$P_w = \frac{1}{2} \pi \rho R^2 V_w^3 \quad (9)$$

Where P_m is the mechanical power that is extracted from the wind by the wind turbine, $w P$ is the actual wind power, ρ is the air density, R is the blades radius of the wind turbine, V_w is the wind speed and C_p is the efficiency index [6]. The efficiency index (C_p) represents the part of the actual wind energy that is extractable by wind turbine.

4.2. BESS-STATCOM

Battery Energy Storage System (BESS) have recently uncertainty of supply, unbalanced and distorted power supply. It emerged as one of the most promising storage technology. The BESS connected at point of common coupling (PCC) acts as a source of leading or lagging reactive current in order to regulate PCC voltage with variation of load.

The most important function of the BESS is to provide active power, kW to the system. The maximum kW output of the BESS will be primary factor dictating the rating of the PCS. The storage capacity of the battery bank depends upon the nature of compensation being provided. When power fluctuation occurs in the system, the BESS can be used to level the power fluctuation by charging and discharging operation. The battery is connected in parallel to the dc capacitor of STATCOM [12]. The current control strategy is included in the control scheme that defines the functional operation of the STATCOM compensator in the power system.

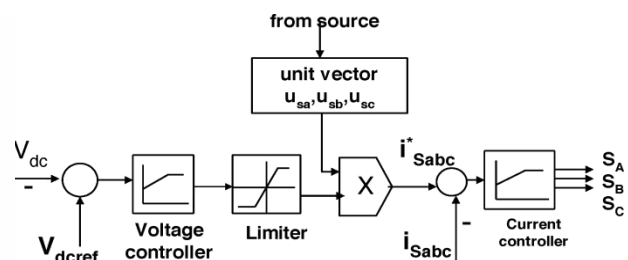

Fig. 4. Control system scheme

4.3. PROPOSED CONTROL SCHEME

The current control scheme for STATCOM is using a "hysteresis current controller." Using this technique, the controller keeps the STATCOM current between boundaries of hysteresis area and gives correct switching signals for STATCOM operation [13]-[14]. It is a feedback current control method where the actual current tracks the reference current within a hysteresis band. The current controller generates the firing pulses to the VSI by comparing the reference and actual current.

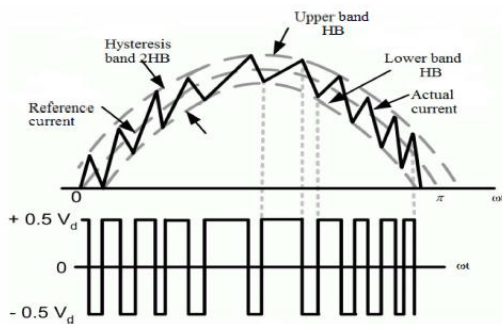

Fig 5: Hysteresis current modulation.

The hysteresis current control scheme for generating the switching signals to the STATCOM is shown in Fig.5. If the current exceeds the upper limit of the hysteresis band, upper switch of the inverter arm is turned off and the lower switch is turned on. As a result, the current starts to decay.

If the current crosses the lower limit of the hysteresis band, the lower switch of the inverter arm is turned off and the upper switch is turned on. As a result, the current gets back into the hysteresis band. Hence, the actual current is forced to track the reference current within the hysteresis band. The choice of the current band depends on the value of compensation current and the interfacing inductance.

V. SIMULATION PERFORMANCE

The performance of the system is analysed with and without STATCOM by switching ON the STATCOM at time $t=0.7s$. Initially the STATCOM current is zero after 0.4 seconds the STATCOM starts tracking the reference current within the hysteresis band which is shown in Fig 6.

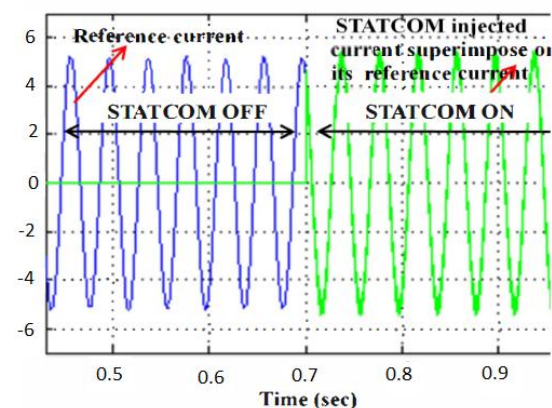

Fig.6. STATCOM injected current superimposed on its reference current.

When STATCOM controller is made ON, without change in any other load condition parameters, it starts to mitigate for reactive demand as well as harmonic current. The result of source currents

shown in Fig. 7. Initially Source current is not in phase with voltage during STATCOM OFF condition and in ON condition grid current is 180° out of phase with voltage, which signifies that the excess power after feeding the RL load is fed back to the grid which is shown in fig 7 and 8 respectively.

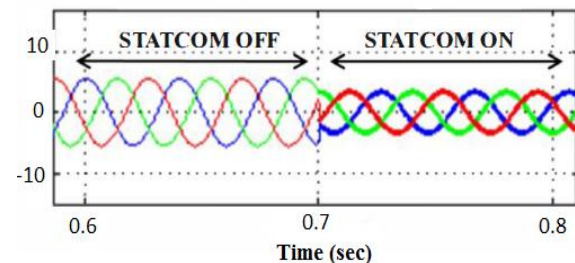

Fig.7. source current

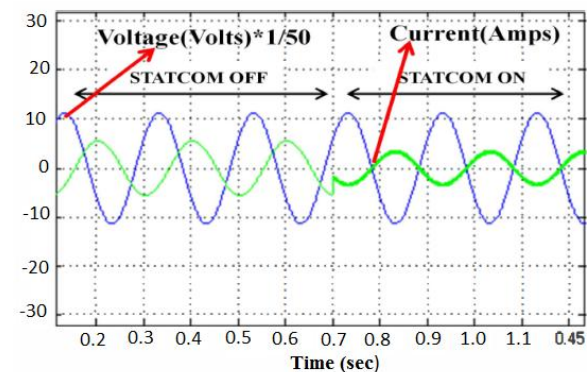

Fig.8. Instantaneous Value of grid Voltage and current for one phase.

The source current with and without STATCOM operation is shown in Fig. 10. This shows that the unity power factor is maintained for the source power when the STATCOM is in operation. The current waveform before and after the STATCOM operation is analysed.

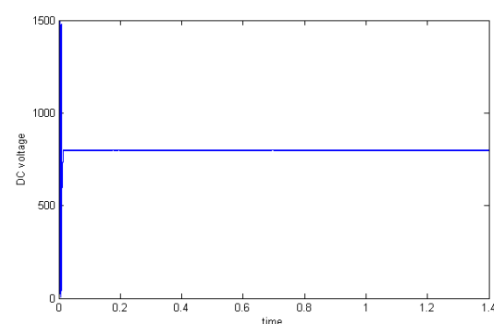

Fig9(a)

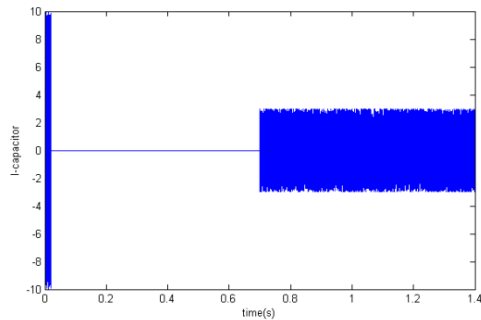

Fig 9.(a)DC link voltage.(b)current through capacitor

The DC link voltage regulates the source current in the grid system,so the DC link voltage is maintained constant across the capacitor as shown in fig9(a).The current through the dc link capacitor indicating the charging and discharging operation as shown in fig.9(b)

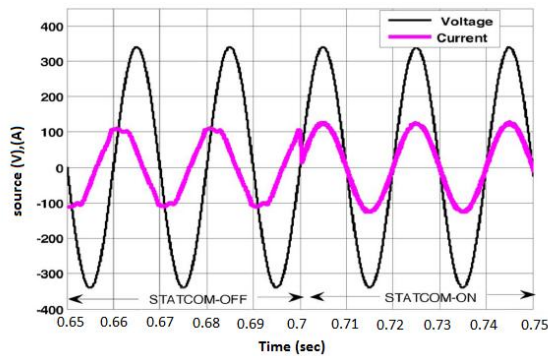

Fig 10. Supply Voltage and Current at PCC.

The inverter output voltage under STATCOM operation with load variation is shown in Fig. 11.

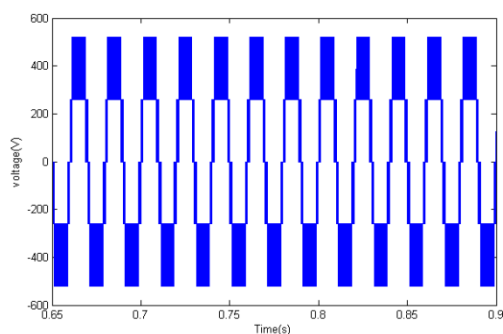

Fig.11.Output Waveform of inverter.

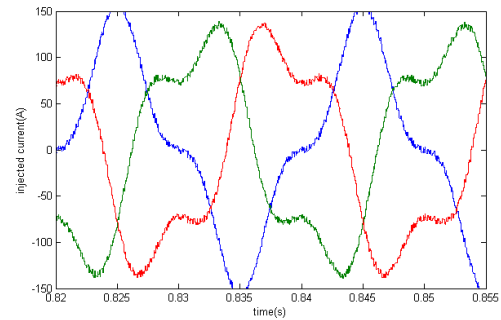

Fig 12.Three phase injected inverter current

The batteries is also supported by the controller of this inverter.The three phase inverter injected current are shown in fig.12

The Fourier analysis of this waveform is expressed and the THD of this source current at PCC without STATCOM is 4.71%, as shown in Fig. 13.

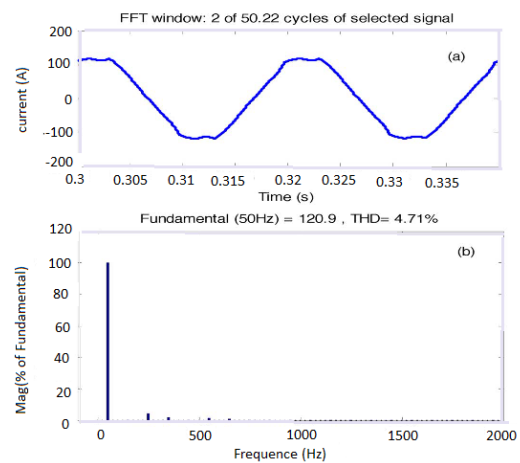

Fig.13. (a) Source Current. (b) FFT of source current.

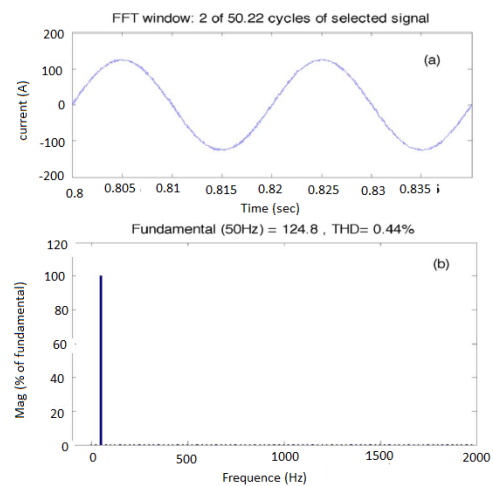

Fig.14. (a) Source Current. (b) FFT of source current.

VI. CONCLUSION

The paper presents the STATCOM-based control scheme for power quality improvement in grid connected DFIG. The power quality issues and its consequences on the consumer and electric utility are presented. The operation of the control system developed for the STATCOM-BESS in MATLAB/SIMULINK for maintaining the power quality is simulated. A STATCOM is proposed for dynamic voltage control, particularly to suppress the short-term (seconds to minutes) voltage fluctuations. Finally, a STATCOM control strategy for voltage fluctuation suppression is presented, and the dynamic simulations are used to verify the performance of the proposed STATCOM and its control strategy. It has a capability to cancel out the harmonic parts of the load current. It maintains the source voltage and current in-phase and support the reactive power demand for the wind generator and load at PCC in the grid system, thus it gives an opportunity to enhance the utilization factor of transmission line. The integrated wind generation and STATCOM with BESS have shown the outstanding performance. Thus the proposed scheme in the grid connected system fulfills the power quality norms as per the IEC standard 61400-21.

REFERENCES

- [1] Analysis, Modeling and Control of Doubly-Fed Induction Generators for Wind Turbines by ANDREAS PETERSSON ISBN 91-7291-600-1 Nyserie nr. 2282.
- [2] Electrical Generators by Taylor & Francis Group, LLC. 2006 Chapter 2.
- [3] Fadaeinedjad, R., Moschopoulos, G., and Moallem, M. Using statcom to mitigate voltage fluctuations due to aerodynamic aspects of wind turbines. Power Electronics Specialists Conference (2008), 3654-3648. 1, 2
- [4] Grunbaum, R. Voltage source converters for maintaining of power quality and stability in power distribution. European Conference on Power Electronics and Applications (2005).
- [5] Advanced Electric Drives, year 2001 Edition, Ned Mohan, published by MNP PERE
- [6] Matlab Simulink as Simulation Tool for Wind Generation Systems Based on Doubly Fed Induction Machines by MoulayTahar Lamchich and Nora Lachguer
- [7] Singh, B., Saha, R., Chandra, A., and Al-Haddad, K. Static synchronous compensators (statcom): a review. IET Power Electronics 2 (2009), 297-324. 1
- [8] Mohod.S.W and M. V. Aware, "Grid power quality with variable speed wind energy conversion," in Proc. IEEE Int. Conf Power Electronic Drives and Energy System [PEDES], Delhi, Dec. 2006.
- [9] Indian Wind Grid Code Draft report on, Jul. 2009, pp. 15-18, C-NET.
- [10] F.Blaabjerg, Z.Chen, S.B.Kjaer., "Power Electronics as efficient interface in dispersed power generation System." IEEE Trans. On Power Electron. Vol.19, No.5, pp.1184-1194., Sept.2004
- [11] Sung-Hun, Seong R Lee, Hooman Dehbonei, Chemmangot V. Nayar, "Application Of Voltage-and Current-Controlled Voltage Source Inverters for Distributed Generation System." IEEE Trans. On Energy Conversion, Vol.21, No.3, pp. 782-788, Sept.2006
- [12] R. S. Bhatia, S. P. Jain, D. K. Jain, and B. Singh, "Battery energy storage system for power conditioning of renewable energy sources," in Proc. Int. Conf. Power Electron Drives System, Jan. 2006, vol. 1, pp. 501-506.
- [13] Leszek S. Czarnecki, 'Instantaneous Reactive Power p-q Theory and Power Properties of Three-Phase Systems' IEEE Trans on power delivery', vol. 21, no. 1, Jan 2006.
- [14] K. Derradji Belloum, and A Moussi, 'A Fixed Band Hysteresis Current Controller for Voltage Source AC Chopper', World Academy of Science, Engineering and Technology 45 2008.
- [15] Tazil, M., Kumar, V., Bansal, R. C., Kong, S., Dong, Z. Y., Freitas, W., & Mathur, H. D. (2010). Three-phase doubly fed induction generators: an overview. IET Electric Power Applications, 4(2), 75-89.
- [16] S.N.Bhadra, D.Kastha and S.Banerjee text book of "wind electrical power system"
- [17] J. J. Gutierrez, J. Ruiz, L. Leturiondo, and A. Lazkano, "Flicker measurement system for wind turbine certification," IEEE Trans. Instrum Meas., vol. 58, no. 2, pp. 375-382, Feb. 2009.
- [18] T. Kinjo and T. Senjyu, "Output leveling of renewable energy by electric double layer capacitor applied for energy storage system," IEEE Trans. Energy Conv., vol. 21, no. 1, Mar. 2006.



Mr.K.Suresh was born on 01-07-1987.He received the B.Tech (Electrical and Electronics Engineering) degree from the Rajeev Gandhi memorial college of engineering and technology in 2005. He did his M.Tech (PE) from Rajeev Gandhi memorial college of engineering and technology in 2009.Currently he is working as an Assistant Professor in Department of EEE inRajeev Gandhi memorial college of engineering and technology,Nandyal. His area of interested in Power Quality improvement power Systems



Mr.B.Raghu was born on 15-10-1989, He received the B.Tech degree in Electrical and Electronics Engineering from G.pullareddy engineering college (Autonomous) in 2011. Currently he is pursuing his M.Tech., from, Rajeev Gandhi memorial college of engineering and technology,Nandyal AP. His area of interest are Electrical Machines & Drives and Renewable Energy generation through wind