

Real Power Flow Control in Transmission Line Using TCSC with Fuzzy Controller

A Sivasankar¹, Dr.T.S.Sirish²

¹M.Tech (PSCA) Department of EEE, GVP College of Engineering (Autonomous)

²Professor, Department of EEE,

GVP College of Engineering (Autonomous) srinivas.sirish@gvpce.ac.in

ABSTRACT

In modern days the necessity of electrical power is increased due to rapid industrial development. The sudden increment in the demand, affect the power system stability and power flow. There is a need of enhancement in the power transfer capability of existing AC transmission system and power flow control. FACTS devices are used for controlling the power flow in the transmission line. In this paper, the performance of TCSC is examined by comparing the real power flow in transmission system with and without TCSC. In an open loop control, the power flow in transmission line has been controlled by changing the firing angle manually and this process is very difficult to maintain the desired power flow in the transmission line. A closed loop control is required to avoid the manual control and maintain the desired power flow in the transmission line. A fuzzy controller is designed to provide automatic control for TCSC to maintain the desired power flow in the transmission system and verified the bi-directional real power flow control using TCSC with FLC. The simulation is carried out by using MATLAB Simulink software package.

Keywords-: TCSC, Flexible AC transmission system, Power Transfer Capability, Fuzzy Logic Controller, Real Power Flow (RPF).

Date of Submission: 31-08-2017

Date of acceptance: 13-09-2017

I. INTRODUCTION

Power system is divided into Generation, Transmission and Distribution systems. Transmission system is an interconnected system which carries power from generation station to load centers. Generator station generates power to meet the demand and maintain the system stable. The load on the power grid is continuously changing and it increases drastically due to the industrial development. So the power system engineers are facing the problems to meet the demand with existing transmission system. The power transfer capability can be increased by connecting a new transmission line parallel with the existing transmission line, but it is more cost effective and difficult. To enhance the power transfer capability of transmission system FACTS Devices are used. For improving the power transfer capability and transmitted power of transmission lines, series compensation is a cost-effective and effective method. TCSC is a series compensating device which is connected in series with the transmission line.

The AC power flow on transmission system is limited by series reactive impedance of transmission system. The main purpose of series compensation is to reduce the transmission line

reactance. In FSC, Fixed Capacitor is added in series with the transmission line. The series capacitor reduces the part of the reactive impedance of the line then the effective impedance value of the line is decreased and the power flow in the line is increased. The major drawback of FSC is fixed compensation and discontinuous control operation. TCSC is a most effective device to control the power flow in the line and improve the power transfer capability and it provides the fast and smooth control of line impedance.

II. SYSTEM DISCRPTION

In this paper, a two area system model is implemented. Two areas are connected by a transmission line called tie line. The figure below represents a single line diagram of a two area system model. The real power flow 'P' at the receiving end is $P = \frac{V_s \cdot V_r}{X_L} \sin(\delta_s - \delta_r)$.

III. TCSC MODULE

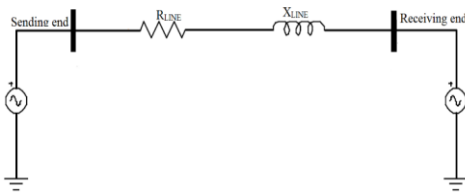

Fig 1: Single line diagram of two area system model

The basic TCSC module is a combination of fixed capacitor (FC) in parallel with a Thyristor Controlled Reactor (TCR). The TCR is a combination of reactor in series with the anti-parallel connected thyristor valves with a firing angle ranging from 90^0 to 180^0 with respect to the capacitor voltage. The effective inductive reactance of TCR is varied from finite value (jX_L) to infinite (∞). The minimum value (X_{TCRMIN}) of TCR branch is obtained at firing angle $\alpha = 90^0$ and the maximum value (X_{TCRMAX})

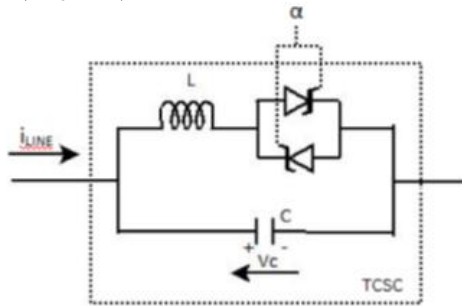

Fig 3: Basic TCSC module

of TCR branch is obtained when $\alpha=180^0$ where TCR act as open circuit. The net reactance (X_{TCSC}) of TCSC is a parallel connection of capacitor and the actual reactance of TCR as shown below.

$$X_{TCSC}(\alpha) = \frac{-jX_C * jX_{TCR}(\alpha)}{jX_{TCR}(\alpha) - jX_C}$$

$$X_{TCR}(\alpha) = \frac{\pi * X_{TCR}}{2(\pi - \alpha) + \sin(2 * \alpha)}$$

X_{TCSC} is a function of firing angle (α). The variation of TCSC module reactance X_{TCSC} with firing angle or delay angle (α) is shown below in Fig.3. TCSC operated in three regions which are inductive region,

Range of firing angle(α)	Region
$90 < \alpha < \alpha_{Lmax}$	Inductive Region
$\alpha_{Lmax} < \alpha < \alpha_{Cmin}$	Resonance Region
$\alpha_{Cmin} < \alpha < 180$	Capacitive Region

Fig 3: Basic TCSC module

capacitive region and resonance region. TCSC should not operate in the resonance region because during this period of operation the device voltages and currents are very high and the device offers very high impedance which leads a high voltage drop across the device.

Characteristics of TCSC:

The TCSC characteristics are obtained using MATLAB and the results are shown in Fig4. If the firing angle is increased from the 90^0 to 138^0 , TCSC acts as variable inductor and the region of operation is known as inductive region and the firing angle varying from 150^0 to 180^0 .

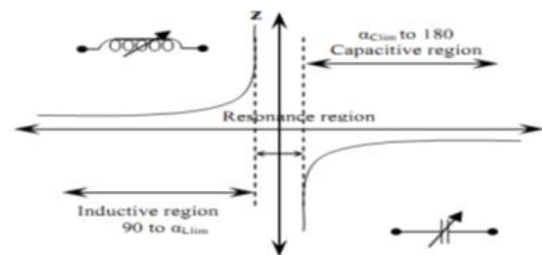

Fig 4: Characteristics of TCSC

TCSC acts a variable capacitor and the region of operation is known as capacitor region. For firing angle from 138^0 to 150^0 , TCSC offers high impedance and it operates in resonance region.

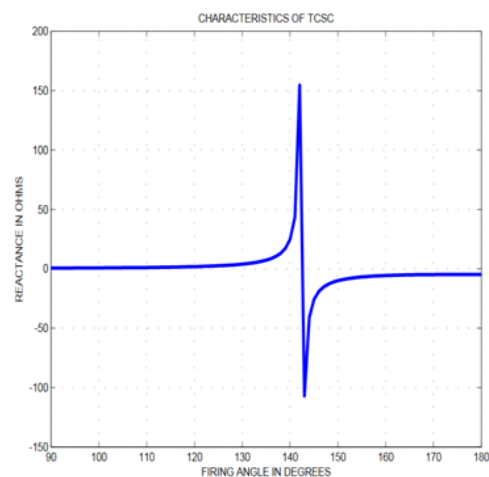

Fig 5: Characteristics of TCSC

IV.DESIGN OF FUZZY CONTROLLER

Fuzzy logic control gives more advantages in real time applications. Fuzzy logic controller (FLC) is designed based on set of rules

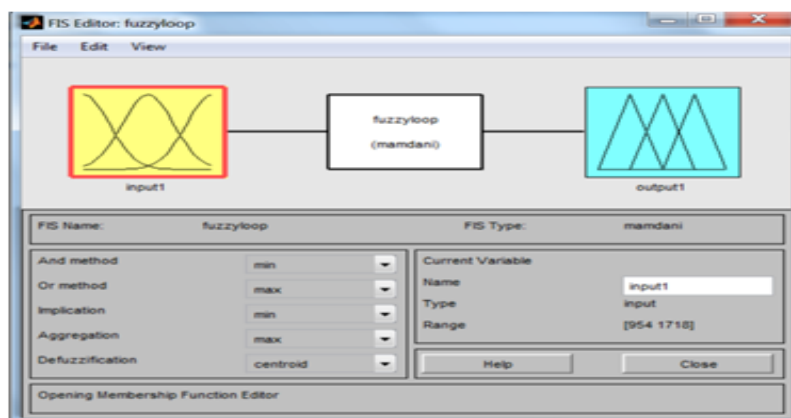

Fig 6: Fuzzy editor in MATLAB

(rule based controller). The set of rules are developed based on the application. The decision making mechanism gives the output for the given inputs based on rules. The fig 6 shows the structure of fuzzy logic controller in matlab.

Fuzzification: Fuzzification is a process of transforming the input crisp value into the fuzzy value.

Defuzzification: Defuzzification is process of transforming the fuzzy value into the crisp value. Centroid method is used in defuzzification.

Interface: Interface provides the set control actions based on the fuzzy input variables. Mamdani fuzzy interface is based on the implication method.

The input to the fuzzy controller is reference power flow in system and output of the controller is delay angle. The input and output membership functions of controller are shown below.

V. SIMULATION RESULTS

TCSC Modeling In MATLAB Simulink:

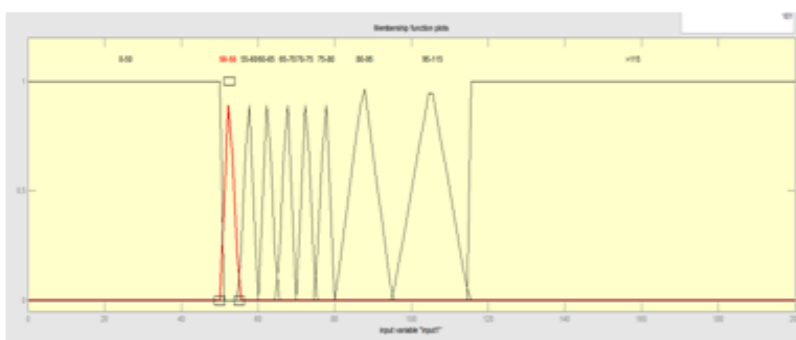

Fig 7: Input membership functions

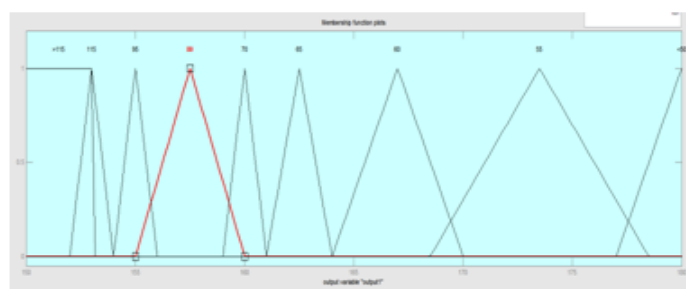

Fig 8: Output membership functions

The simulation of two area system model with and without TCSC done in MATLAB SIMULINK is shown in fig 9 and fig 10 respectively.

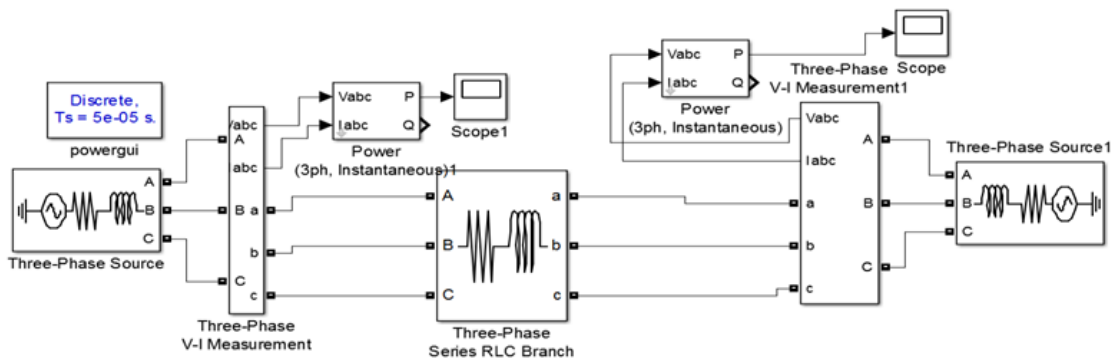

Fig 9: Two area system without TCSC

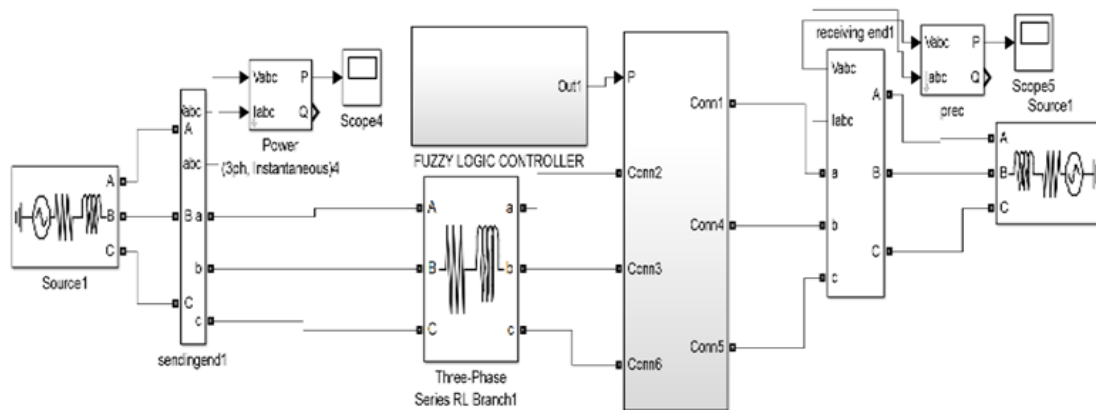

Fig 10: Two area system with TCSC

Fuzzy controller is used to control the power flow in transmission line in a closed loop control.

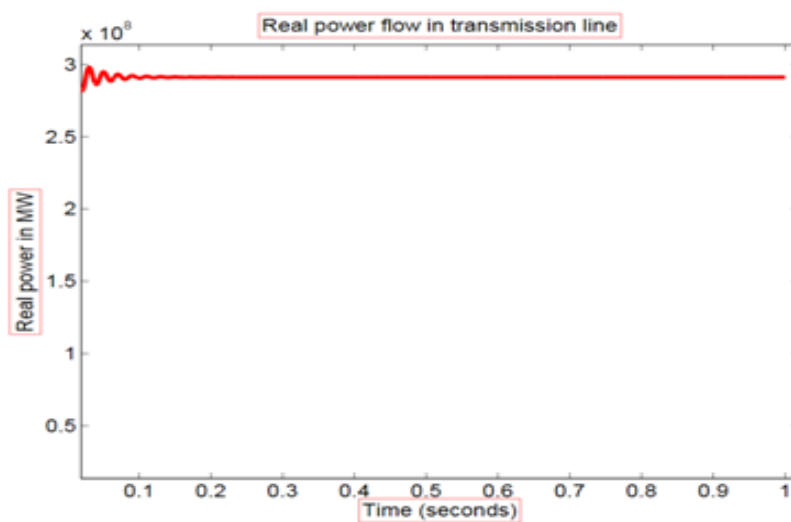

Fig 11: Real power flow in transmission line for uncompensated system

The power flow variations in the transmission line without TCSC are shown in Fig 11.

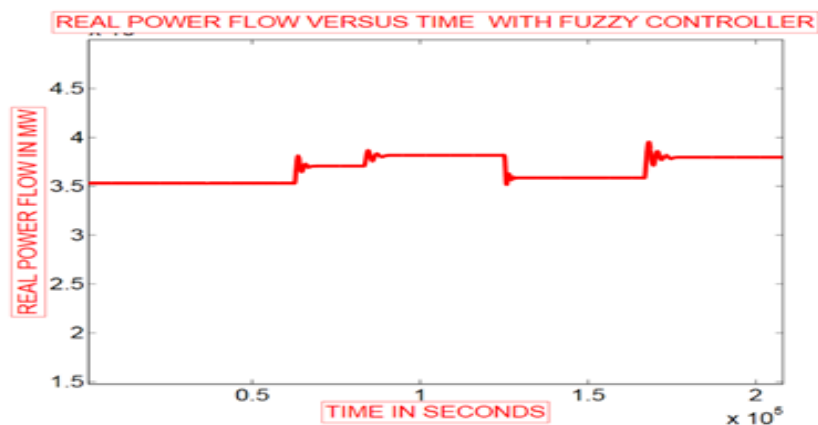

Fig 12: Real power flow in transmission line using TCSC with FLC from area1 to area2

The power flow variations in the transmission line with TCSC are shown below Fig 12. The simulation results show the variation of power flow improvement in transmission line with TCSC.

The bi-directional characteristics of a two area system are verified in MATLAB Simulink and the

simulation results are verified with mathematical calculations. The Fig 13 below shown represents the bi-directional RPF control using TCSC with FLC.

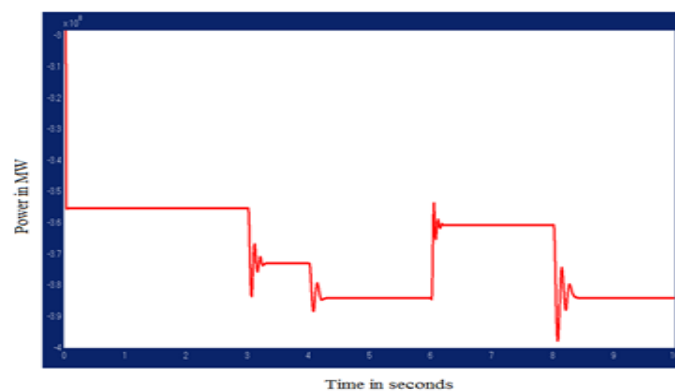

Fig 13: Real Power Flow Control in transmission line using TCSC with FLC from area2 to area1

VI. CONCLUSION

TCSC can be used to enhance the power flow in the transmission system. In an interconnected system TCSC is more effective device to control the power flow and avoid over loading of transmission system and also improves the power transfer capability and transient stability of a system. Fuzzy controller is more effective in real time applications.

A closed loop control is required to avoid the manual control and maintain the desired power flow in transmission line and this can be achieved by using fuzzy controller and also verified the bi-directional real power flow control using TCSC with FLC.

REFERENCES

- [1]. Sonam and V. K. Garg, "A Characteristics & Behavioral Study Of TCSC Device Using MATLAB/SIMULINK," vol. 6, no. 4, 26th July 2016.
- [2]. N. Banda, S. Sikder, P. Acharjee and J. Gunda, "Preparation Modelling Of TCSC For Control And Enhancement Of Power Flow," 2nd International Conference On Advances In Engineering And Technology (ICAET), March 28th & 29th, 2012.
- [3]. N.G. Hingorani and Gyugyi, *Understanding FACTS Concepts And Technology Of Flexible AC Transmission Systems*, New York: IEEE Press, 1999.
- [4]. M. German-Sobek, B. Ubomir and C. Roman, "Using Of The Thyristor Controlled

- Series Capacitor In Electric Power Sytem,"
Electroenergetik, vol. 4, no. 4, 2014.
- [5]. P. Singh, L. Mathew and S.Chatterji,
"MATLAB Based Simulation Of TCSC
FACTS Controller," N.I.T.T.T.R,
Chandigarh Proceedings Of 2nd Conference
On Challenges & Opportunities In
Information Technology (COIT), 2008.
- [6]. S.Balamurugan, K.Manjusha and N.Kirtika,
"Real Power Flow Control In Transmission
System Using TCSC," Biennial International
Conference On Power And Energy Systems
(PESTESE), 2016.
- [7]. S.Rajasekaran and G. V. Pai, Neural
Networks, Fuzzy Logic And Genetic
Algorithms: Synthesis And Applications,
PHI Learning pvt.Ltd, 2013.
- [8]. C. R. Alvala, Fuzzy Logic And Neural
Networks: Basic Concepts & Applications,
New Age International Publishers.

International Journal of Engineering Research and Applications (IJERA) is **UGC approved** Journal with Sl. No. 4525, Journal no. 47088. Indexed in Cross Ref, Index Copernicus (ICV 80.82), NASA, Ads, Researcher Id Thomson Reuters, DOAJ.

A Sivasankar. "Real Power Flow Control in Transmission Line Using TCSC with Fuzzy Controller." International Journal of Engineering Research and Applications (IJERA) , vol. 7, no. 9, 2017, pp. 55–60.