

DESIGN OF PROGRESSIVE DIES

K.Kishore Kumar¹, Dr. A.Srinath², M.Naveen³, R.D.pavan kumar⁴

^{1,3.} Assistant Professor, Research Scholar, Dept.of Mechanical Engg, K L University

² Professor, Department of Mechanical Engineering, , K L University,

^{4.} Mtech (CAD/CAM) K.L.UNIVERSITY

Abstract

Before converting raw materials to a finished product we need an accurate design of the product and also data required for manufacturing. If the design is not accurate then defects will occur in the manufactured product; small mistakes in designing a product makes the manufactured product useless so more amount time is allotted for designing a new product (or) for modifying the existed design.

In this work the use of a software namely Pro/E for designing a progressive die to manufacture washer for the M 12 bolt has been incorporated. A progressive die is a multiple station die. In this work authors have designed a progressive die which has two stages of operation. The former operation is piercing and is followed by blanking. In both operations a finite volume of metal is removed from the sheet metal.

If the final product happens to be removed portion then the operation is blanking, on other hand if pierced sheet metal is the final product then the operation is piercing. Both the operations are performed simultaneously in a single stroke of press, thus enabling the user to obtain the final product in a single stroke. This design procedure can also be extended for manufacturing washers for M-series bolts by modifying the punch and die plate dimensions.

Key words: *Progressive dies, washers, Design, forces for punching and blanking*

1.DESIGN OF PROGRESSIVE DIE

A progressive die performs a series of fundamental sheet metal operations at two or more stations during each press stroke in order to develop a work piece as the strip stock moves through the die. The work piece on progressive dies travels from one station to another, with separate operations being performed at each station. Usually the work piece is retained in the stroke until it reaches the final station, which cuts off the finished piece. All station work simultaneously at different points along the work strip, which advances on station at each stroke of ram. Thus a complete part is produced with each stroke. Progressive dies generally include blanking and piercing operations but a complicated progressive die can do the operation of bending, forming, curling and heading also. Each workstation performs one or more distinct die operation, but the scrip must move from the first through each succeeding station to produce a complete part. One or more idle station may be incorporated in the die, not to perform work on the metal but to locate the strip, to facilitate inter station strip travel, to provide maximum size die sections or to simplify their construction.

The operation performed in a progressive die could be done individual dies as separate operations but would require individual feeding and producing. In a progressive die the part remains connected to the stock strip, which is fed through the die with automatic feeds and positioned by pilots with speed and accuracy.

The linear travel of the strip stock at each press stroke is called the progression, advance or pitch and is equal to the interaction distance.

The unwanted parts of the strip are cutout as it advances through the die, and one or more tabs are left connected to each partially completed part to carry it through the stations of the die. Sometimes parts are made from individual blanks, neither a part of, nor connected to a strip in such cases mechanical fingers or other devices are employed for the station to station movement of work piece.

The selection of any multi-operation tool, such as progressive die, is justified by the principle that the number of operations achieved with one handling of the stock and produced part is more economical than production by a series of single operation dies and a number of handling for each single die.

Where tool production requirements are high, particularly of production rates are large, totally handling cost is saved by progressive fabrication compared with a series of single operation are frequently greater than the costs of the progressive die.

A progressive die should be heavily constructed to withstand the repeated shock and continuous runs to which it is subjected, precision guide post and bushings should be used to maintain accuracy. Lifters should be provided in die cavities to lift up or eject the formed parts and carrier rails or pins should be provided at the last station. When practical, punches should contain shudder or kicker pins to aid in disposal of slugs. Adequate piloting should be provided to ensure proper location of the strip as it advances through the die. The stripper plates should engage guides before contacting the strip.

The dropping of the work pieces through the die is the most desirable method of part ejection, but cannot always be obtained. Cutting the scrap in to small section simplifies the material handling problems and produces a greater price and return when sold as scrap metal.

In the present project the progressive die set is used to produce component that is washer the specification are as follows

Stock strip material is mild steel.

Thickness of strip : 1.6mm

Outer diameter : 26mm

Inner diameter : 12.5 mm

2.PRINCIPLE OF METAL CUTTING:-

The metal is brought to the plastic stage by pressing the sheet between two shearing blades so that fracture is initiated with the movement of the upper shear, finally result in the separation of the slug from the parent strip.

The metal under the upper shear is subjected to both compressive and tensile stresses. In an ideal shearing operation. The upper shear pushes the metal to a depth equal to about the third of its thickness. Because of pushing the material into the lower shear the area of cross-section of the metal between the cutting edge of the shear decreases and causes the initiation of the fracture. The portion of the metal which is forced into the lower shear is lightly burnished and would appear as a bright band around the blank lower portion. The fractures which are initiated at both the cutting points would progress further with the movement of the upper shear and if the clearance is sufficient, would meet, thus completing the shearing action.

The two shearing elements of the press tool are the hardened punch and the die plate having sharp edges and a certain shearing clearance. Both the shapes of the punch and the die opening conform to the required shape of the component. The punch is connected to the ram of the power press and while descending contacts the stock, exerts pressure over the stock around the cutting edges and shears it through. Exactly the same phenomenon that takes place where in blanking (or) in piercing (or) in any other shearing operation.

In the process of shearing four important stages are usually distinguished according to the observation.

STAGE I: Plastic Deformation

The stock material has been placed on the die and the punch is driven towards the die. The punch contacts the stock material and exerts pressure upon it. When the elastic limit of the stock material is exceeded, plastic deformation takes place.

STAGE II: Penetration

As the driving force of the ram continues, the punch is forced to penetrate the stock material and the blank or slug is displaced into the die opening a corresponding amount. This is true shearing part in of the cutting cycle, from which the term "shearing action" is derived.

STAGE III: Fracture

Further continuation of the punching pressure that causes fractures to start at the cutting edges of the punch and the die. Under proper cutting conditions, the fractures extended toward each other and meet. When this occurs, the fracture is complete and the blank or slug is separated from the original stock material. The punch then enters the die opening, pushing the blank or slug slightly below the die cutting edge.

STAGE IV:

As the punch completes the down stroke up to the lower point, the component of slug is pushed through the die opening. Strictly speaking this action is a consequence of the dynamic fracture at the stage III and only in certain case the push through takes place where the punch takes place where the punch travels beyond the land of the die.

This is the simplest approach on the shearing action. Before dealing with the details of the phenomenon, the attention is drawn on the same other allied factors which calls for deeper deliberations on the shearing process.

3.THE AMOUNT OF SHEARING CLEARANCE PER SIDE

At a certain value of shearing clearance, which depends on the thickness, kind and its heat treated conditions of the stock, the crack line meet, resulting in easy action, low vertical force, low horizontal force, low stripping, low wear high die life but fairly distorted sheared contour. At narrower clearance secondary cracks develop that is the two cracks do not meet, resulting in unfavorable increase in forces but some improvement is found in the quality of the cut contour, due some burnishing of the shaped secondary cracks.

Importance of cutting clearance

Proper cutting clearance is necessary to the life of the die and the quality of the piece part. Excessive cutting clearance results in objectionable piece part characteristics, insufficient cutting clearance causes undue stress and wear on the cutting members of the tool because of greater punching effort required. If the amount of clearance is optimum, then the two fracture lines meet and a clean edge is obtained after the operation.

If the clearance is too small then the fracture lines miss each other and a secondary deformation taken place resulting in an unclear edge.

When the amount of clearance is too large obvious that significance amount of drawing action takes place and the quality of the work piece is again quite poor.

Importance of angular clearance

Angular clearance is of vital importance in any die where blanks or slugs pass through the die opening. Like cutting clearance, angular clearance is a "per side" measurement. A clearance of ¼ per side is suggested for die work of good quality when the stock material is less than 1.5mm thick. All die-opening walls should have smoothly finished surfaces throughout. Owing to the lessening of the back pressure from blanks or slugs, small or delicate punches will also benefit from slightly increased angular clearance in the die opening.

(4)..FORCE CALCULATIONS

Punching and Blanking

The punching and blanking process cannot strictly speaking grouped under forming operations. In these processes a finite volume of sheet metal is removed by using a die and a punch. The shape and size of the portion removed are determined by the geometry of the die and the

punch. If the final product happens to the removed portion, then the operation is termed as blanking. On the other hand if the pierced sheet metal is the final product then the operation is called punching.

Blanking

It is a process in which the punch removes a portion of material from the stock which is a strip of sheet metal of the necessary thickness and width . The removed portion called a blank and is usually further processed to be of some use.

Piercing:-

This operation consist of simple hole punching is piercing is making holes in a sheet it is identical to blanking except if the fact that the punched out portion coming out through the die in piercing is scrap .piercing is always accompanied by the blanking operation either before , after(or) at the same time.

Punching Force

The force required to be exerted by the punch in order to shear out the blank from the stock can be estimated from the actual shear area and shear strength of the material using formulae

$$P=L \times T \times \tau$$

$$\tau \rightarrow \text{shear strength (mm)}$$

$$L \rightarrow \text{perimeter of cut (mm)}$$

$$T \rightarrow \text{stock thickness (mm)}$$

Shearing force (F_{sh}):

$$F_{sh} = L \times T \times \tau$$

$$L = \text{Length of cutting edge}$$

$$T = \text{Thickness of the stock strip}$$

$$\tau = \text{shear strength of the material Newton/sq.mm}$$

Force required for piercing operation :

$$F_1 = L \times T \times \tau$$

$$= \pi \times 12.5 \times 1.6 \times 390$$

$$= 24504.4 \text{ N}$$

Force required for blanking operation:

$$F_2 = L \times T \times \tau$$

$$= \pi \times 26 \times 1.6 \times 390$$

$$= 50969.199 \text{ N}$$

Total shearing force :

$$F = F_1 + F_2$$

$$= 75473.62 \text{ N}$$

Taking factor of safety = 1.5

The capacity of press required is 113.21KN

Blank Holding Force:

Blank holding force or stripping force is the force, which controls the metal flow .It is the force applied by the blank holder on the blank to

control the flow of the metal in to the die cavity. Important consideration in tooling for sheet metal forming wrinkling of sheet as it is being formed. Hold down can best be provided by hold down ring .However by using mechanical spring or an auxiliary air cylinder ,hold down can be provided in a single action press.

Stripping force required $=k \times L \times T \times \tau$

K =stripping constant
 $=0.0207$ (for low carbon steels above 1.5 mm thickness)

$$=0.0207 \times \pi \times (12.5+26) \times 1.6 \times 390$$

$$=497.3N$$

$$=0.4973KN$$

Total force= shearing force+stripping force

$$=113.21+0.4973$$

$$=113.70KN$$

Capacity of press required for punching operation=113.7KN

SPRING DESIGN

Spring are used to obtain the required blank holding forces :

Spring has to take up the total force and it should be designed for this load.

P_{max} =Shearing force+blank holding force

$$=113700N$$

Springs has to be designed for this force

$$\delta/n=(8 \times W \times D^3)/(Gd^4)$$

δ =deflection of spring

n =number of active coils

W =axial load in spring

D =mean diameter

G =modules of rigidity for

spring material

d =diameter of spring wire

In the present project

$$\delta =10mm$$

$$D=22mm$$

$$W=113700N$$

$$10/n=(8 \times 113700 \times 22^3)/(84000 \times d^4) \text{-----(1)}$$

We also know that

Free length of spring

L_f =Solid length + maximum compression+clearance between adjacent coils

$$=n \times d + C + 0.15 \times C$$

Where n = n

C =max compression

$$L_f=35mm$$

$$35=nd+10+0.15 \times 10 \text{-----(2)}$$

Solving (1)&(2)

$$n=3 \text{turns}$$

$$d=12.00mm$$

$$D=22mm$$

5)DESIGN OF DIE ELEMENTS USING PRO/E

(5a)DIE BLOCK DESIGN:

A tool-steel block which is bolted to the bed of a punch press and into which the desired impressions are machined. The part of an extrusion mold die holding the forming bushing and core.

The die block constitutes the female half of the two mated tools, which carry the cutting edges. A vertical opening extending through the block determines the size and outline of the blank. The exact opening is provided in the die to obtain a predetermined clearance between punch and the die. The amount of angular clearance and vertical land in the die opening is necessary in order to prevent the possibility of a blank or slug jamming in the passage.

The overall dimensions should be obtained by having minimum die wall thickness required for strength and by the is space needed for mounting screws, dowels, and stripper plate. The material to be used in manufacturing is HCHC and to be heattreated60-62HRC.

Using pro/E software a new file is opened in part mode. The sequence of commands are used.

Select the plane→front→ok

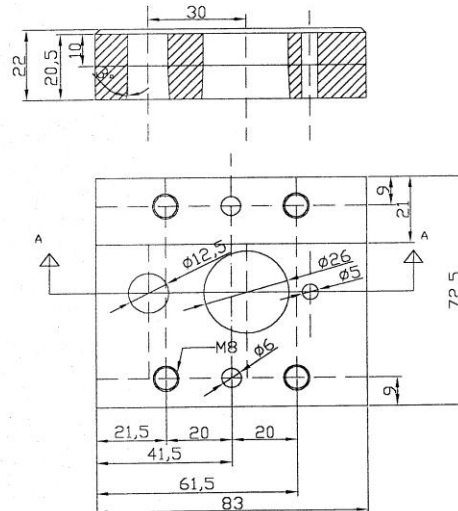

fig5a:2D OF DIE BLOCK DESIGN:

After completion of these command a proper sketching plane is selected to draw the sketch as shown in the drawings and depth is given to the 2-D sketch such that solid model is obtained. Change PRO/E default units to user specified units from menu manager.

Select a plane give direction of sketching plane a new window sketcher arises on the screen. Toggle off the grid and refresh, draw a rectangle

with given dimensions specify the depth of the die plate (rectangle)

Select the part -> extrude -> done

Select a proper plane and give direction of cut specify dimensions for the cutting portions. Give Thru all -> done -> ok for creating hole in die plate of specified dimensions.

Feature->sketch->circle->ok

For standard hole set ISO standards and select proper screw size add thread surface click on thru all, thru thread ,select primary reference plane select linear reference plane1 and plane2 with given distances check the preview and ok A signal standard hole is created.

Feature->copy->mirror->dependent->done

Select a feature to be mirrored, select a plane to mirror, the standard hole using copy command created, four standard holes using cut command remove material up to specified depth to have a step.

Feature->extrude->remove->thru all

Draw rectangle on the top surface of the die plate highlighted entities be aligned. Specify step depth, die plate of 3D progressive die plate with specified dimensions is created.

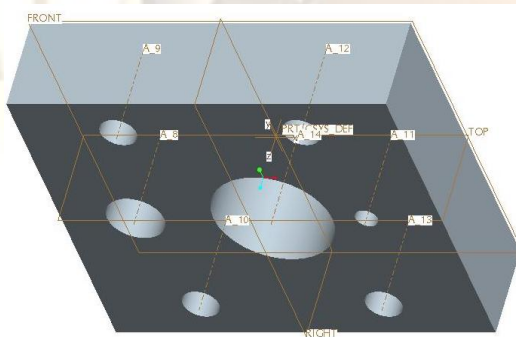

FIA 5A: 3DMODEL

The similar steps are repeated for stripper plate, punch plate , top and bottom plates.

5b)DESIGN OF STRIPPER PLATE

The primary purpose of a stripper is to remove the stock from the punch after a blanking or piercing operation. However the stripper serves two other secondary function also. Firstly it guides the strip if fixed to the die block surfaces. Secondly, it holds the blank under pressure before the punch descends fully if the stripper is of spring loaded type. The thickness of stripper is 14.3mm and the material used is EN 8.

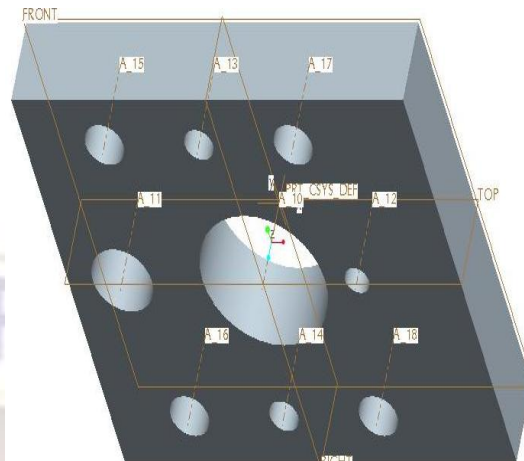

Figure:5(b)3D DESIGN OF STRIPPER PLATE

5c)DESIGN OF PUNCH PLATE

Punch plate is essentially sheet metal with regularly spaced holes and is used to classify material in applications from dredges to trommels and everything in between. Classification is obviously dependant on the size of the holes and that is dependant on application.

Punch plates hold and support piercing, notching, and cut-off punches. They are usually made of machine steel, but can also be made of tool steel that has been left soft for high grade dies. Punch plates range from small simple blocks for holding single piercing punches to large, precision-machined plates for holding hundreds of perforators

The thickness of punch plate is 15mm and the material to be used in manufacturing is EN8. Upper part of the punch plate is provided with a shank equal in diameter to the ram hole. The shank is locked in position with a side screw.

This part which is dowelled together with the top plate retains or holds the punches. The center distances is picked up or transferred from the hardened die block to eliminate the possibility of misalignment of punches and die openings due to dimensional changes during heat treatment. Holes to receive the body of punches are provided with H7 fit in order to bare a light press fitting.

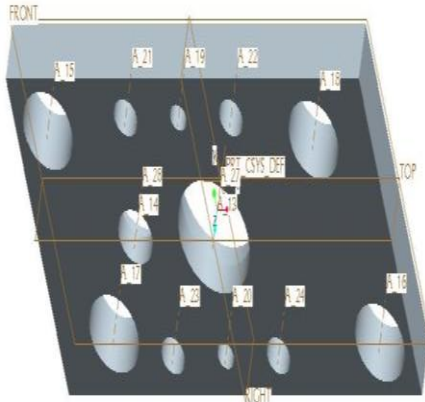
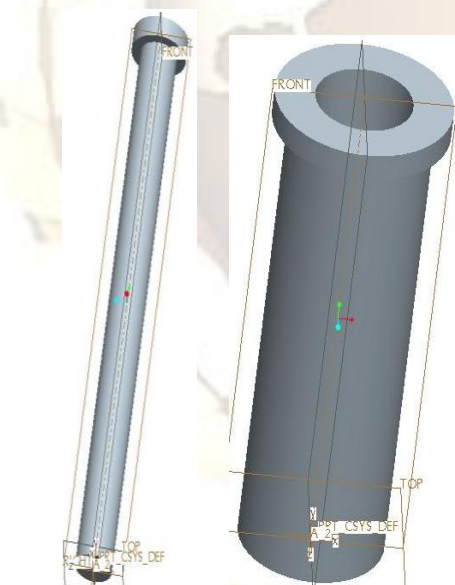

figure5c):3D DESIGN OF PUNCH PLATE
5d)DESIGN OF STOCK GUIDES:

The size of stock guides are dependent upon the size of strip and the size of the die block. Two stock guides (front gage and back gage) of the same size 2'21'83 mm are used. Both the front back games are separate units assembled in the die block. Both are extended and provided with strip rest to aid in aligning the strip for starting and feeding.



Guide
Guide bush

fig5d):DESIGN OF STOCK GUIDES

5E)DESIGN OF PUNCHES:

The exact dimensions of pitch diameter are determined by providing clearance between punch and die. The punch is usually designed with

a wide shoulder to facilitate mounting and to prevent deflection under load

In case of smaller punches the punch may be held in a retainer which in turn is a mounted against the punch holder. The exact length of a punch can be found out by laying the whole assembly drawing only as the sheet height as to be made up from the die block, die shoe, punch , punch holder.

Punches of diameter less than the stock thickness must be designed carefully because unit compressive stress in punches rises 4 times the unit shear stress of the material when punch diameter is equal to stock thickness. The height for these punches are 55mm,the material used for manufacturing in HCHC heat treated to 60-62 HRC . Clearance between punch and die is 0.06mm is selected from the table which is equal to 5-7%.

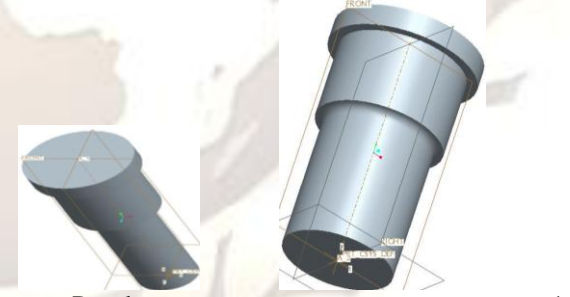
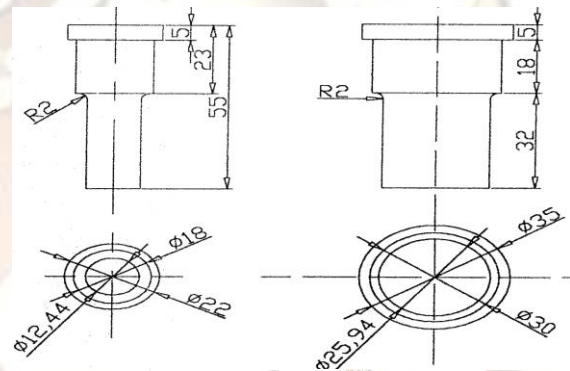

Punch
Punch 2

1

DESIGN OF TOP PLATE

Top plate (upper shoe) holds the upper half component of the die, clamped to the ram by means of the shank being screwed on its top surface where the center of pressure is located .The thickness of the top plate is determined the product of 0.9 times of the thickness of the die block which is equal to 19mm.The material to be used for manufacturing this part is EN8.

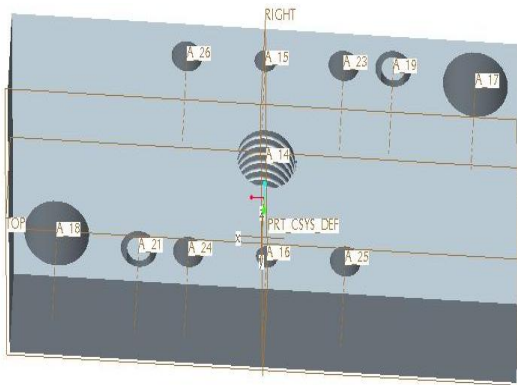

dimensions are based on the standard dimensions of shank sizes. The shank is positioned where the center of pressure is located.

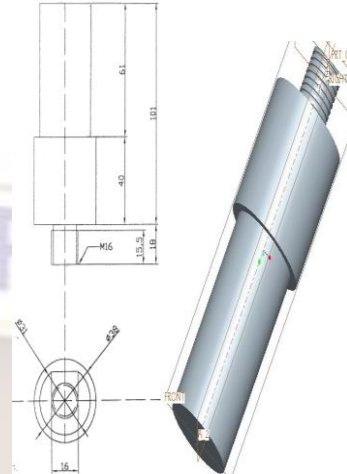

DESIGN OF BOTTOM PLATE

The function of the bottom or lower shoe primarily as a base for the complete die assembly and in turn is bolted or clamped to the bolster plate over the press bed. The thickness of the bottom plate is 16.8mm.

Openings are made with respect to the die openings plus allowance, to allow stamped components to fall freely. The material to be used for manufacturing this part is EN8.

FASTENERS AND DOWELS

Fasteners and dowels are not included in the design for they are available in standard form.

Four M 8 hexagonal socket head screw with length of 25mm each and 2 dowels of 6mm diameter with length of 30mm, are used in the lower half component of the die.

Four M 8 hexagonal socket head screws with length of 75mm, two M 8 hexagonal socket head screw with length of 20mm, two dowels of 6mm diameter with length of 30mm for the lower die.

GUIDE PILLERS AND GUIDE BUSHES

These elements of die are responsible for the alignment of the lower and upper part of the die. It should withstand deflection during continuous production.

Standard dimensions of these parts are used so that manufacturing would not be a problem when these are available in the market

SHUT HEIGHT

It is the distance from the bottom bolster to the top of the punch holder when the die is in the closed position. The shut height will establish the length of guidepost which must be at least 12 mm. starter to allow for the reduced shut height due to resharpening.

The determined shut height is 121.5mm which is the sum of all the thickness of die elements.

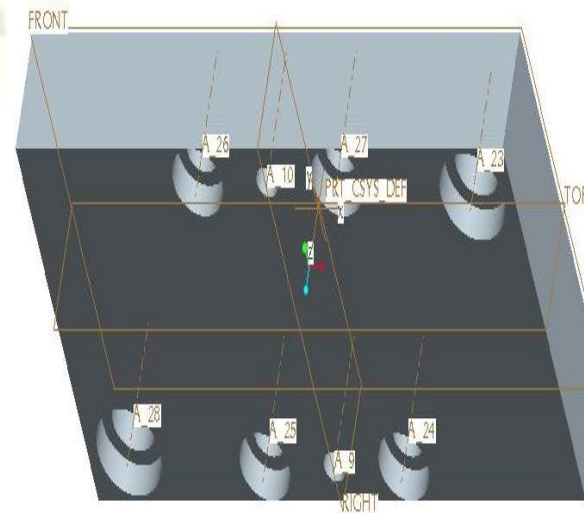

DESIGN OF SHANK

The size of shank is determined with respect to the size of its threaded part (screw) use in holding the top plate. The shank diameter is 31mm. Which is classified under M16 threaded part and holding part length is 60.5mm. The

6.ASSEMBLY OF DIE

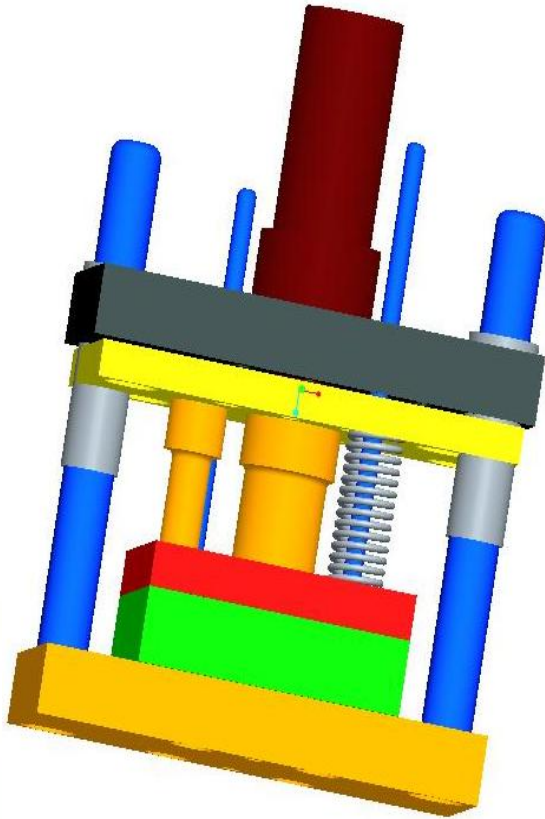

CONCLUSION

By the implementation of computer in design field accuracy of design is improved and design process time is reduced drastically than by traditional method. In the process of creating the documentation for the product design much of required data base to manufacture the product is also created.

Many design problems which are complicated to estimate by traditional methods are eliminated by using CAD system.as the designs have more standardization they can be imported to any other software and also CAD provide better functional analysis to reduce prototype testing

Regarding progressive die design of progressive die is simple. Advantage of progressive die is it perform two or more operations simultaneously by a single stroke. Progressive die is used for high rate of production.

This design procedure can also be extended for manufacturing washers for M-series bolts by modifying the punches and die plate dimension

REFERENCES:

1. Küttner, R. , A Framework for collaborative product and production development system. Proceedings of the 3rd International Conference Industrial Engineering – New Challenges to SME, ed. J. Papstel & B. Katalinic. DAAAM International, Tallinn 2002.pp 34-37
2. Küttner, R., Eljas, O., Teamwork in distributed product development environment. Annals of DAAAM for 2001, Proceedings of 12th International DAAAM Symposium, ed. B. Katalinic. DAAAM International Vienna, Austria 2001.pp 269-270
3. Dieter, G., Engineering Design, McGraw-Hill International Editions, Mechanical Engineering Series, ISBN0-07-366136-8, USA 2000
4. Paquin, J.R. & Crowley, R.E., Die design fundamentals, Industrial Press Inc. Second edition, NY 1987, 244 pp.
5. Küttner, R. & Nekrassov, G. Development of an intelligent integrated environment for computer-aided design of work-holders. Proceedings NordDesign 2002, ed. Per Boelskifte & Johannes B.Sigurjonsson, August 14-16 2002, NTNU, Trondheim, Norway, pp.185-193
6. Progressive Die Wizard Help, EDS 2003
7. A.C.Rao , A.Srinath -Planar linkages: structural influence on mechanical advantage and function generation -- Mechanism and Machine Theory 42 (2007) 472-481